

ACADEMY

HOBBY MODEL KITS

M4A2 SHERMAN

RUSSIAN ARMY



1/35th Scale

13010

M4A2 셔먼 러시아군

The M4A2 Sherman was similar to the M4, with welded hull and cast turret, but was powered with twin GM 6-71 diesel engines. This was the only diesel engine version of the Sherman tank to see service in large numbers. Having a diesel engine, the M4A2 version's engine deck and back end is noticeably different from all other Shermans. The early production model had the 75mm gun M3 in the M34 gun mount and vision slots in the front armor plate. The gun mount was later replaced by M34A1 gun mount, which featured a direct telescope. Some versions were armed with 76mm gun. In later productions, the return rollers were moved to the rear of the bogie mount and the suspension was of the horizontal volute spring type. The M4A2 saw action in the European and Pacific theaters, and was mainly used by the US Marines and lend lease to the Soviet Union, British, and Free French. Over 8000 M4A2 were produced during the middle of World War II.

Der M4A2 Sherman war fast identisch mit dem M4. Er hatte die gleiche geschweißte Wanne sowie den Gussturm, wurde jedoch von zwei 6-71 Diesel von GM angetrieben. Somit war der A2 die einzige Dieselsonversion des Sherman, welche in größeren Stückzahlen in Dienst gestellt wurde. Aufgrund des Motors kam es zur Änderung des Motordecks sowie dem Heck des Panzers, die ersten Produktionslose waren mit dem 75mm M3 Geschütz in der M34 Blende bestückt und hatten Sehslitz in der Frontplatte. Spänderte man die Lagerungen für die Stützrollen hinter den Laufrollenwagen, dann wurde das gesamte Fahrwerk auf horizontale Spiralfederung umgestellt. In Europa wurde der M4A2 bei den Briten (dort Sherman III genannt) und Franzosen eingesetzt, auch bekamen die sowjetischen Truppen eine stattliche Anzahl. Nur auf dem pazifischen Kriegsschauplatz wurde der M4A2 vom U.S. Marine Corps verwendet. Insgesamt produzierte man während des zweiten Weltkrieges über 8000 Stück.

M4A2型シャーマン戦車は、溶接した車体と鑄造された砲塔を持つM4型戦車と同じ戦車ですが、ゼネラル・モーターズ社6-71型ディーゼル・エンジンを動力とする戦車です。同戦車は、多数が就役したシャーマン戦車の中で唯一のディーゼル・エンジン装備型でした。ディーゼル・エンジンを装備することで、M4A2型戦車のエンジン・デッキと車体後部は他の全てのシャーマン戦車と識別できる違いがあります。同戦車の初期生産型は、M34型砲架台に口径75ミリM3型砲を、視界円孔を前方装甲板に持っていました。砲架台は、後に直通の潜望鏡が特徴であるM34A1型に置き替えられました。いくつかのバージョンは76ミリ砲を装備していました。後期の生産型は、後退ローラーがボギー架台の後部に移され、サスペンションは水平渦巻き形のスプリングでした。M4A2型シャーマン戦車は、欧州及び太平洋の戦域の戦闘に参加し、主として米海兵隊により使用され、またソ連軍、英国軍、自由フランス軍にリース貸与されました。第2次世界大戦の中頃に8,000台を超える数のM4A2型シャーマン戦車が建造されました。

M4A2 셔먼은 여러 종류의 셔먼 중에서 유일하게 디젤 엔진을 장착한 형식으로, 외형적으로는 다른 셔먼들과 크게 다르지는 않지만 차체상면의 엔진데크와 후면의 각도, 그리고 하체 후면의 형태에서 큰 차이점을 보여준다. M4A2는 다른 셔먼들과 마찬가지로 차체는 관공을 용접한 방식으로 제작되었으며, 그 위에 주조제의 포탑이 장착되었다. M4A2는 75mm포를 장착한 등근 포탑과 76mm장포신을 장착한 대형 포탑의 후기형 모델이 있으며, 차체 전면 장갑의 경사각에서도 초기형의 60도에서 후기형은 47도로 개수가 이루어졌다. 그리고 차체 하부 및 현가장치는 다른 종류의 셔먼들과 마찬가지로 수직현가 장치(VVSS)를 사용하고 있으며, 그 밖에 장비품이나 형태에서 다른 셔먼들과 크게 달라진 점을 보이지는 않는다. 무장은 75mm 또는 76mm포를 주무장으로 하며, 부무장으로는 차체 전방에 Cal.30 기관총과 주포와 연동하는 Cal.30 동축 기관총을 장착하고, 포탑 상면에 Cal.50 중기관총을 장비하고 있다. M4A2 셔먼은 2차대전 전 기간 동안 유럽과 남태평양 전에서 광범위하게 사용 되었으며, 대부분의 M4A2 셔먼은 미 해병대에 의해서 사용되었지만, 일부는 영국군과 자유프랑스군, 그리고 76mm포를 장비한 후기형은 러시아군에 공여되어 사용되었다. M4A2 셔먼은 2차 대전 기간 동안 모두 8,000여대가 생산되었다.

<READ THIS BEFORE YOU BEGIN>

- Study the instructions before assembling. - Check the fit of each piece before cementing into place.
- Do not use too much cement to join parts. - Never use cement or paint near open flame.
- Open a window or make area well ventilated when cement or paint is in use.
- Tear up and throw away the empty plastic bags to avoid danger of suffocation for little children.

<ALLGEMEINE HINWEISE>

- Die Anordnung der Bauteile ist aus den Zeichnungen der Anleitung ersichtlich.
- Die Teile vor dem Verkleben ungeleimt zusammenhalten, um ihren paßsitz zu prüfen.
- Klebstoff nicht zu dick auftragen. - Klebstoff und Farben niemals in der Nähe einer Flamme verwenden.
- Während der Bemalung mit Spritzpistole oder Pinsel für frische Luftzufuhr, z.B. Öffnung des Fensters, sorgen.
- Bausatz von kleinen Kindern fernhalten. Verhüten Sie, daß Kinder irgendwelche Bauteile in den Mund nehmen oder Plastiktüten über den Kopf ziehen.

■ 조립하기 전에

- 부품을 조립하기 전에 설명서를 잘 읽어본 후 조립한다. -부품을 자를 때에는 칼이나 니퍼로 깨끗이 잘라준다.
- 접착제나 페인트를 사용하며 환기를 잘 한다. -에나멜 페인트나 접착제를 사용할 때는 창문을 열어 환기를 시키고 화기를 멀리한다.

<LISEZ CE QUI SUIT AVANT DE COMMENCER LE MONTAGE>

- Etudier les schémas d'assemblage. - Contrôler que chaque pièce soit bien conforme avant de la coller à sa place.
- N'utilisez pas trop de colle pour réunir les pièces. - Ne faites pas manipuler la colle ou peinture à proximité d'une flamme.
- Aérer soigneusement la pièce où vous peignez (ouvrir la fenêtre). - Après avoir sorti les pièces du sac en plastique, déchirer le sac afin d'éviter que les enfants ne le mettent sur la tête et ne s'étouffent.

<組み立てる前に>

- 組み立てる前に説明書をお読み下さい。 -部品をランナーから切りはなす時は模型用ニッパーとカッターを使用します。
- 接着剤を少なめに使うことがきれいに仕上げるコツです。 -接着する前に部品を合わせて確かめます。
- 接着剤や塗料を使用する時はときどき窓を開けて換気に気をつけましょう。
- 組み立て後の部品やビニール袋は小さな子供の手の届かない安全な所に保管して下さい。

- 접착제를 사용할 곳과 사용하지 않는 곳에 주의하고 너무 많이 바르지 않도록 한다.
- 사용 후 남은 부품은 어린 아이들의 손에 닿지 않도록 잘 처리한다.



접착한다.
Cement parts
Coller
Kleben
Pegar
Incollare
Colar
Kleven



접착하지 않는다.
Do not cement
No pas coller
Nicht kleben
No pegar
Non incollare
Nao colar
Niet kleven



수반을 조립한다.
Repeat operation
Répéter l'opération
Vorgang wiederholen
Repitir la operacion
Ripetere
Repitir a operacão
Herhalen



전사지를 붙인다.
Decals
Déalcomanies
Abziehbild



무게추를 넣는다.
Add weight
Lester
Gewicht



구멍이나 홈을 메워준다.
Use filler
Mastiquer
Schleifen



잘라낸다.
Cut away
Couper
Schneiden
Cortar
Tagliare
Cortar
Snijden



선택한다.
Optional parts
Choix
Auswahlmöglichkeit
Eleccion
Scelta
Opcao
Keuze



반대측도 조립한다.
Repeat for opposite side
Répétition de la page
Wiederholung für gegenüberliegende Seite



구멍을 뚫어준다.
Make hole
Faire un trou
Öffnen



주의한다.
Be careful
Faire attention
Hier Vorsicht



색칠 및 전사지 붙이기 번호
Painting scheme number
Numeros de la liste de peintures
Lackierschemanummer

* () is opposite number. ()는 반대측 번호입니다.
 —▶ Cement 접착합니다.
 - - -▶ Do not cement. 접착하지 않습니다.

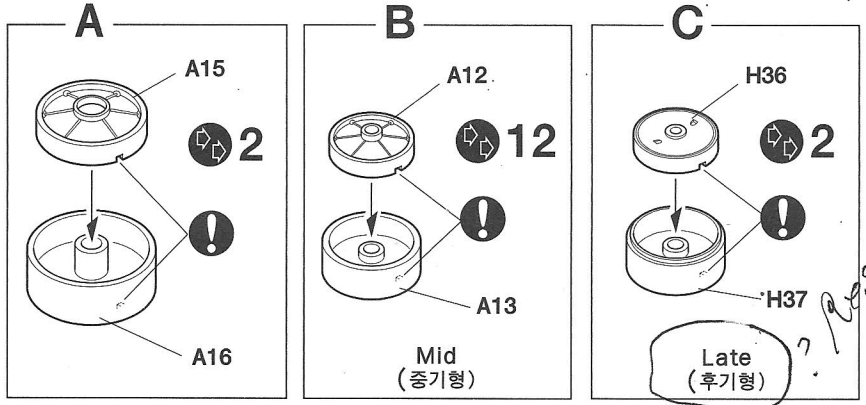
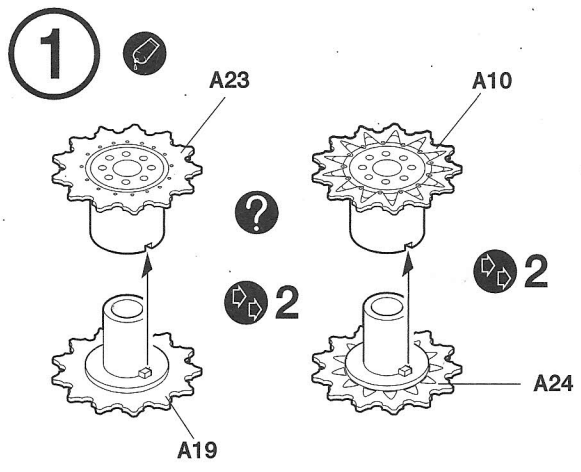

*C is optional parts.
C는 옵션 부품입니다.

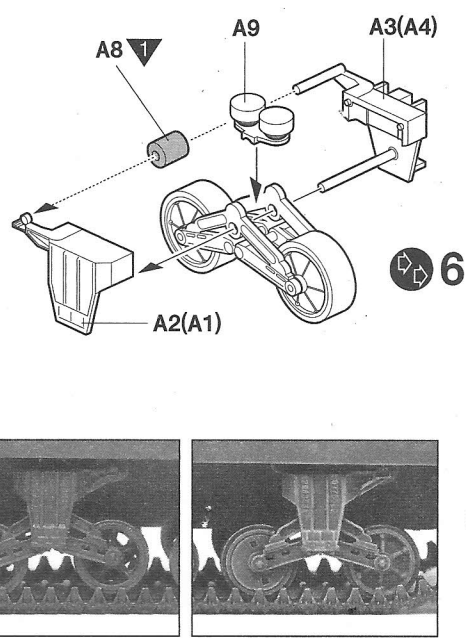
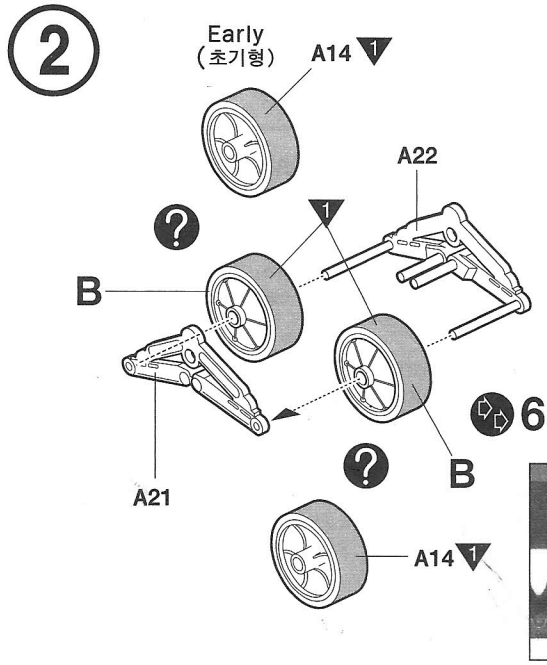

* () is opposite number. ()는 반대측 번호입니다.
 ! Right 우 : A2,A3 3
 ! Left 좌 : A1,A4 3

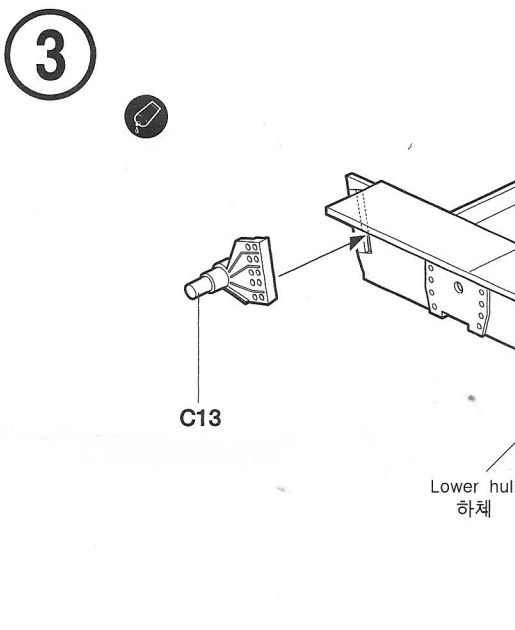

4

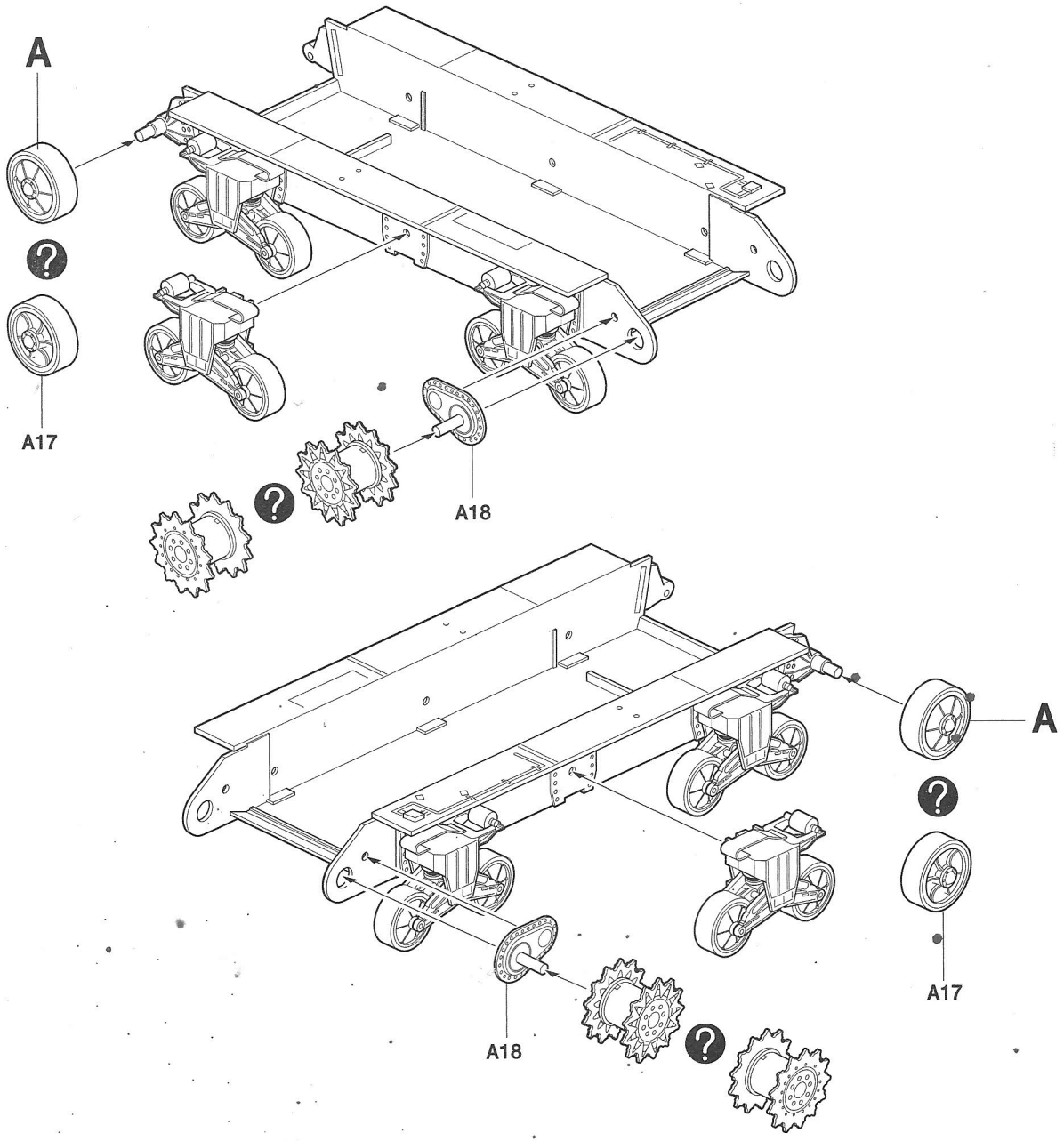

5

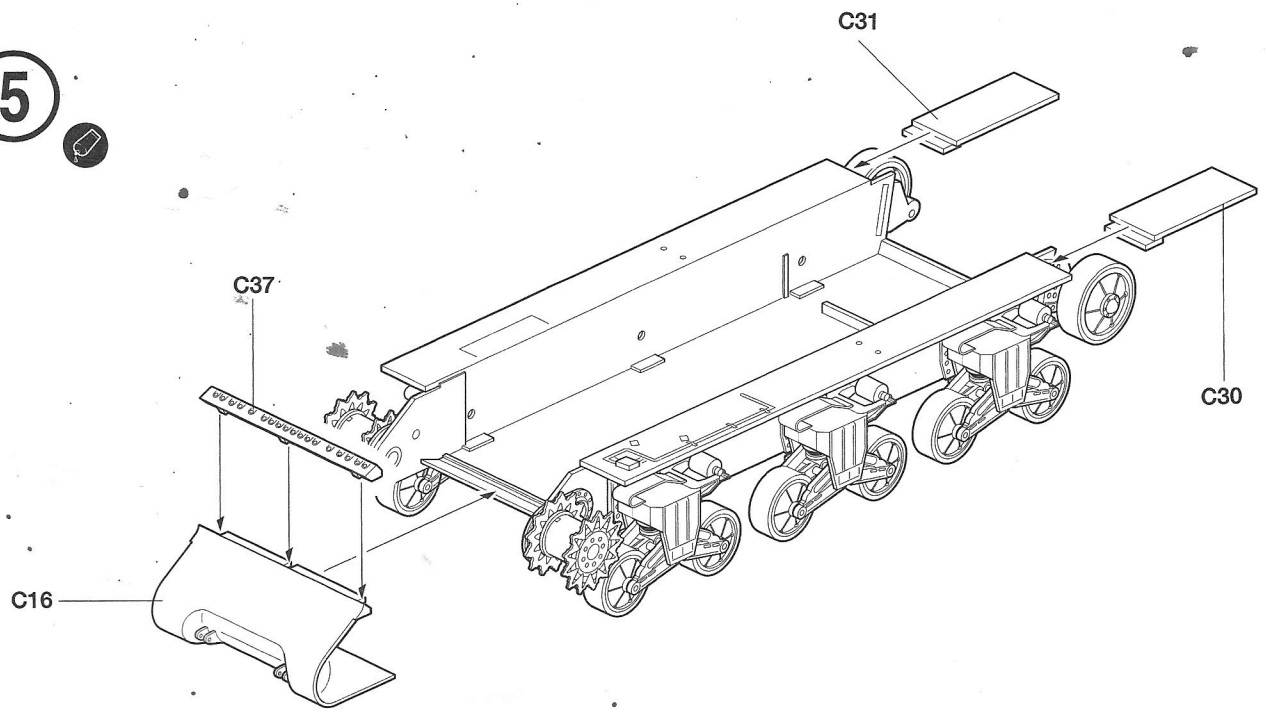

6

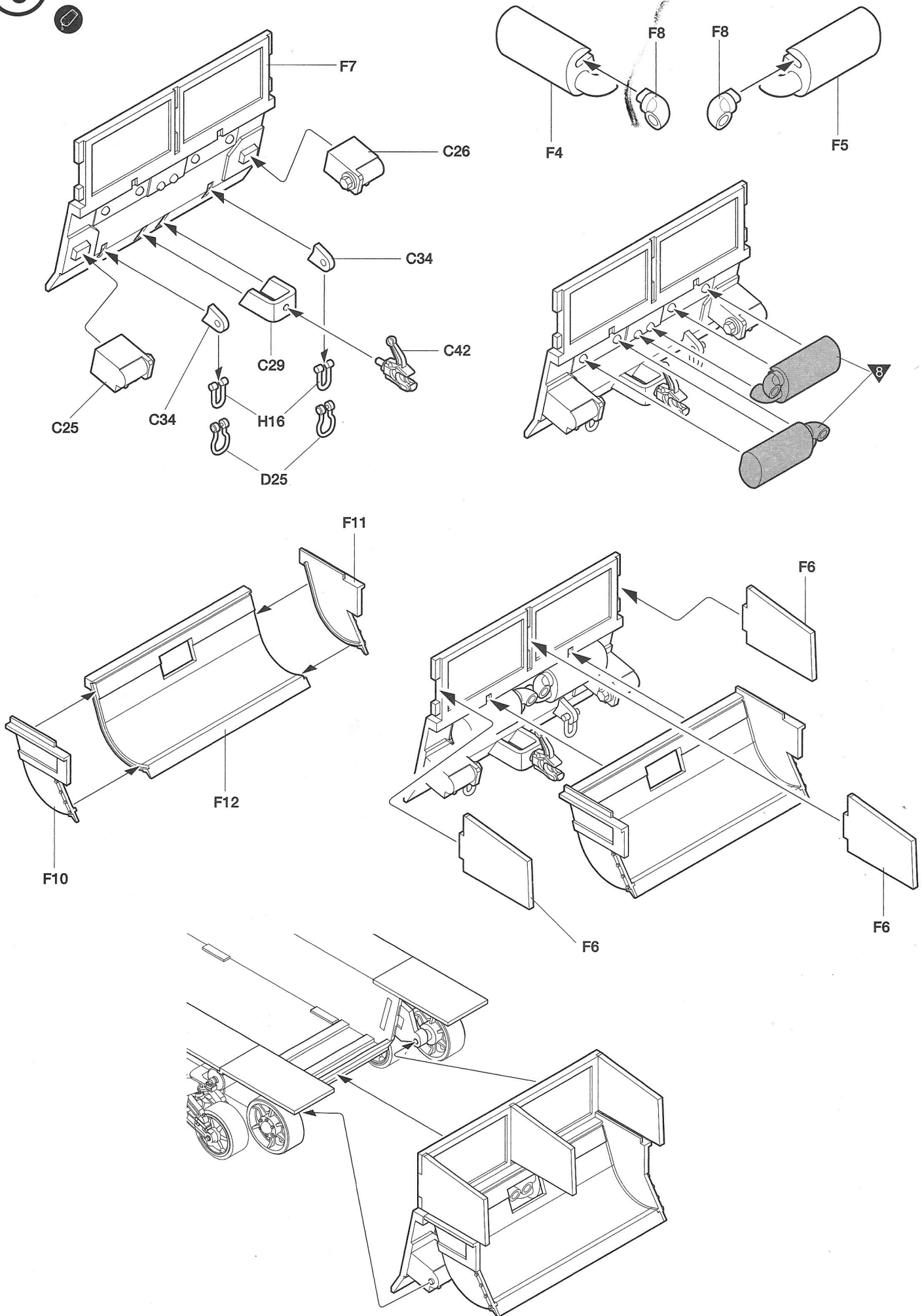

7

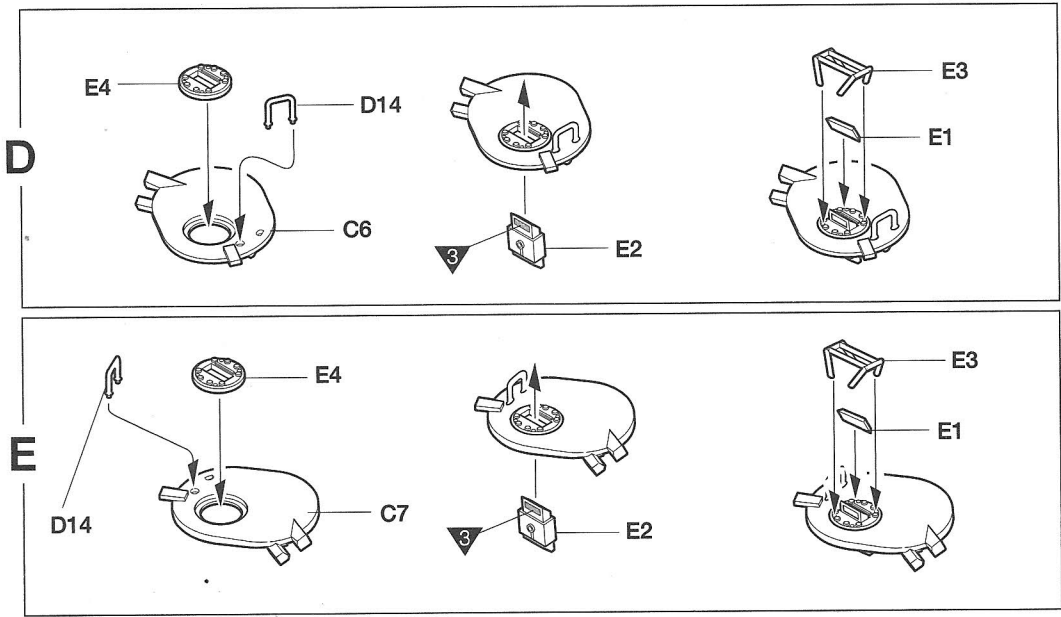

8

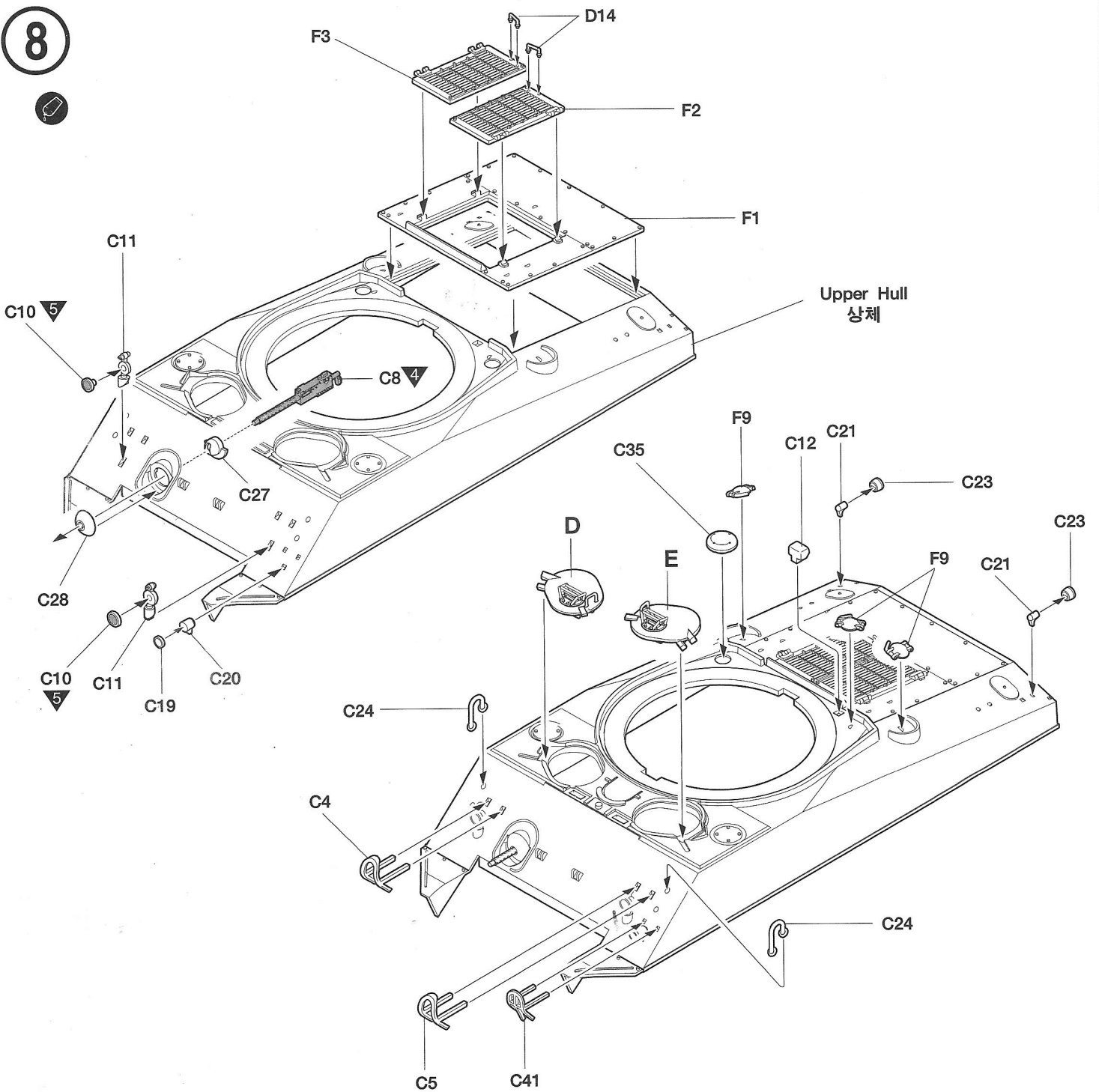

9

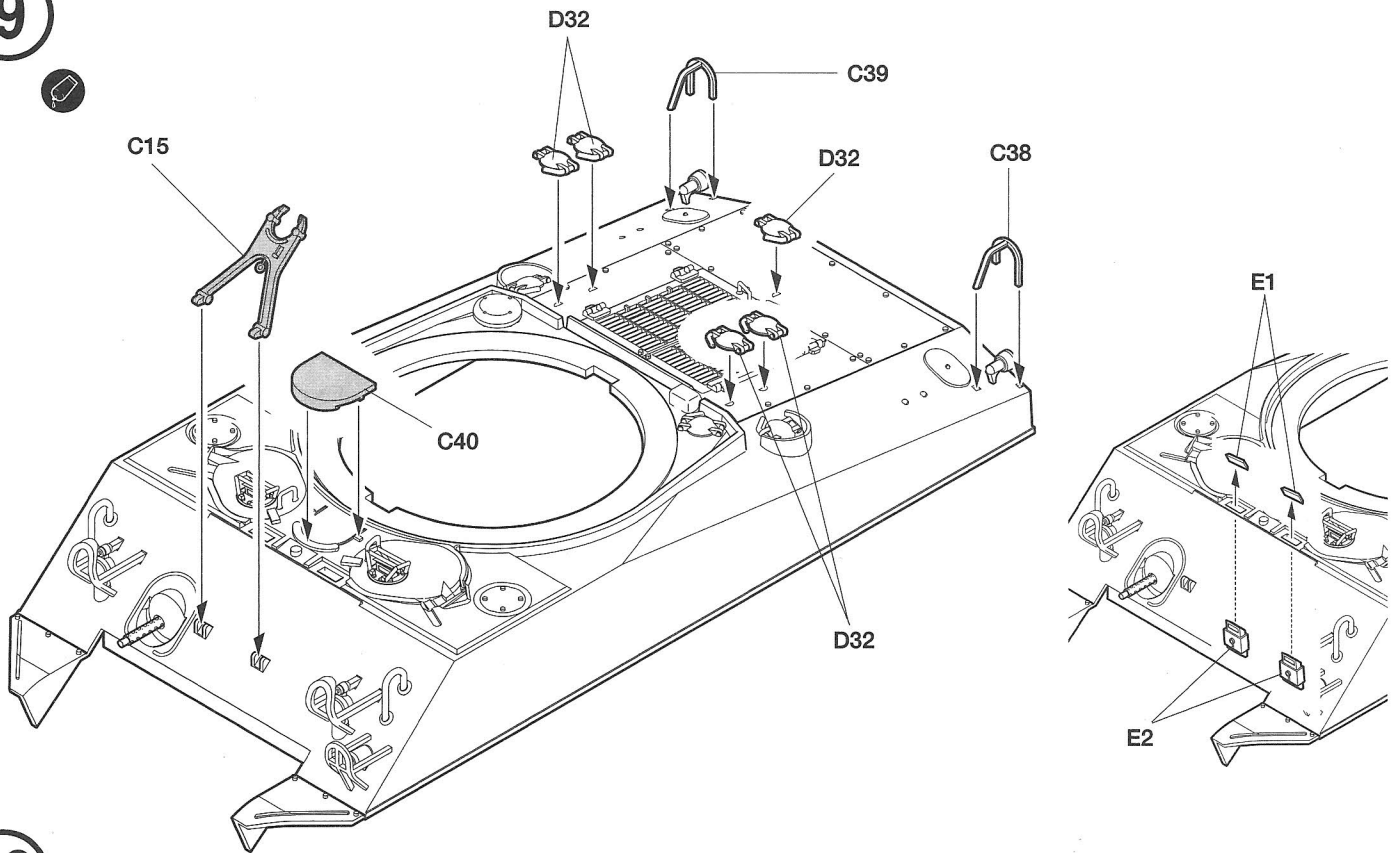

10

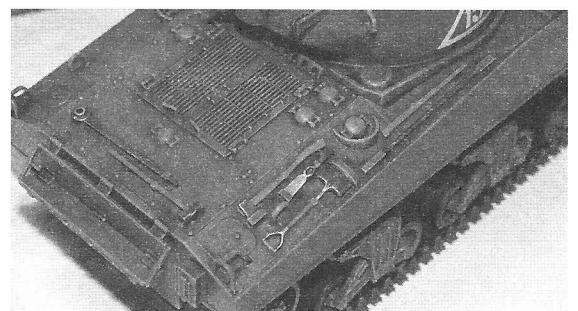
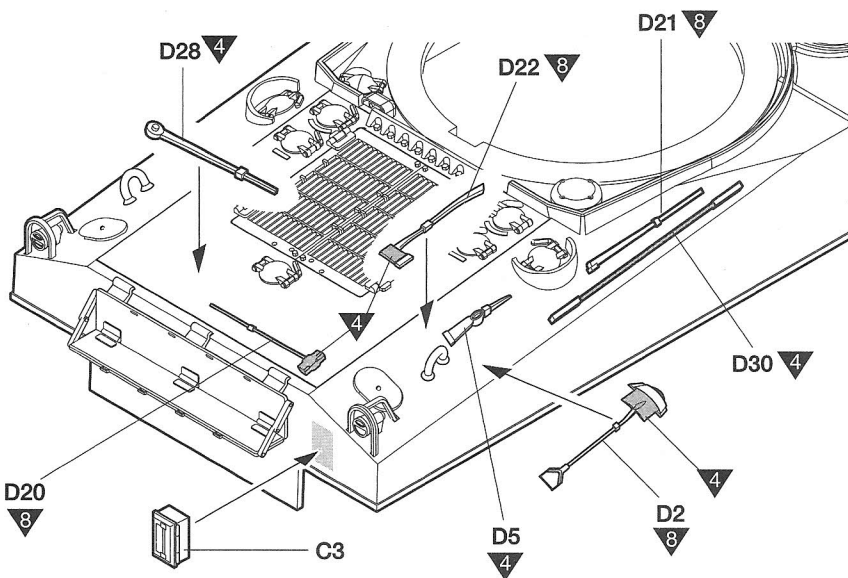
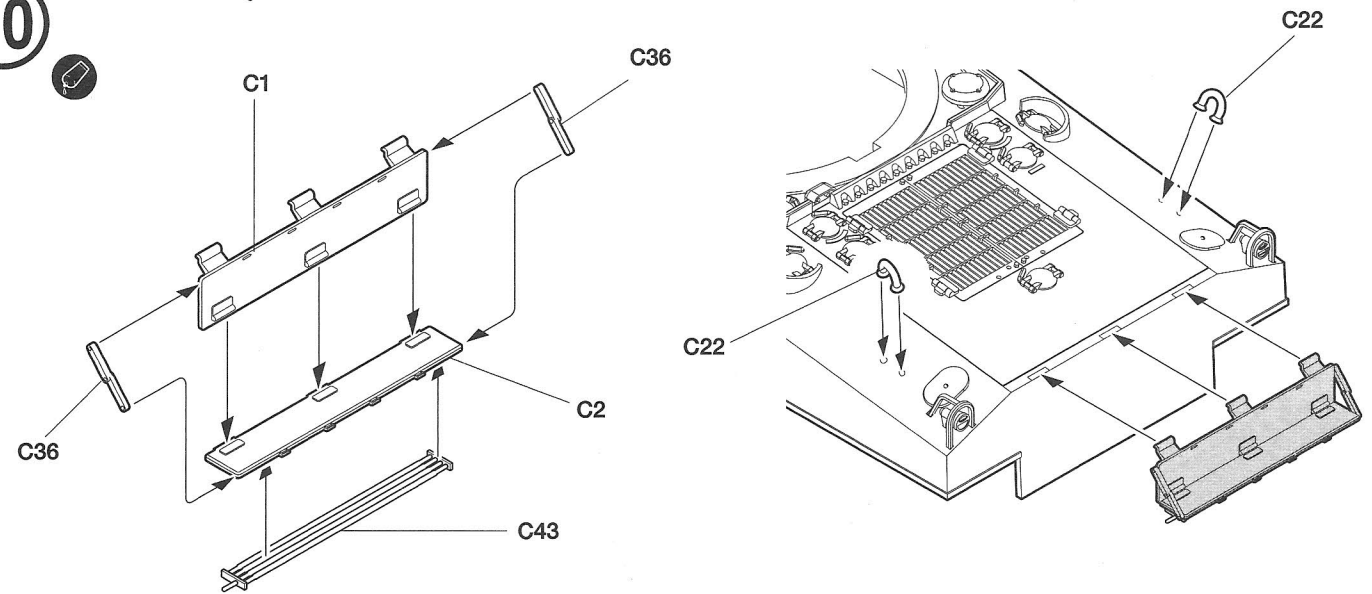

11

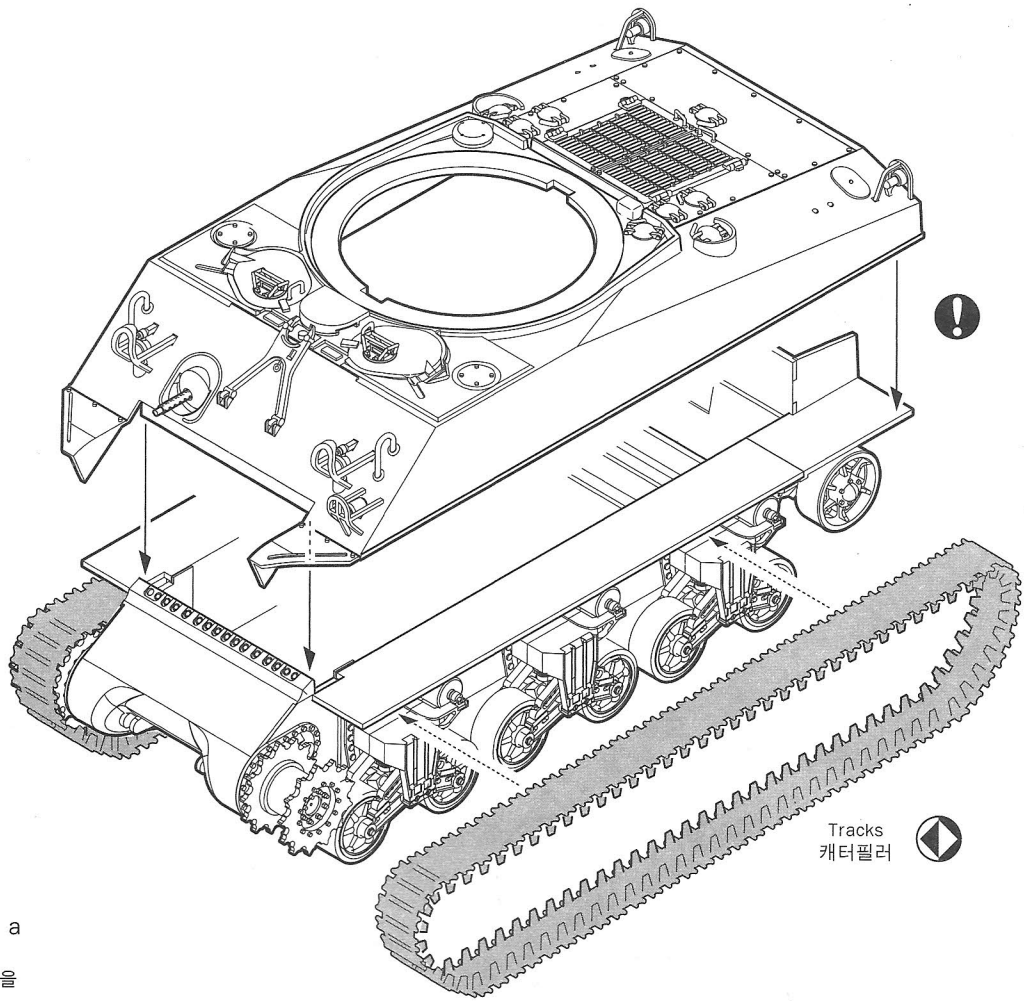

<Tracks 캐터필러>

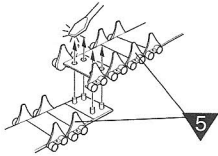

* Melt pins together with a heated screw driver.
볼에 달군 드라이버 등으로 핀을 녹여 고정시켜 연결한다.

Tracks
캐터필러

12

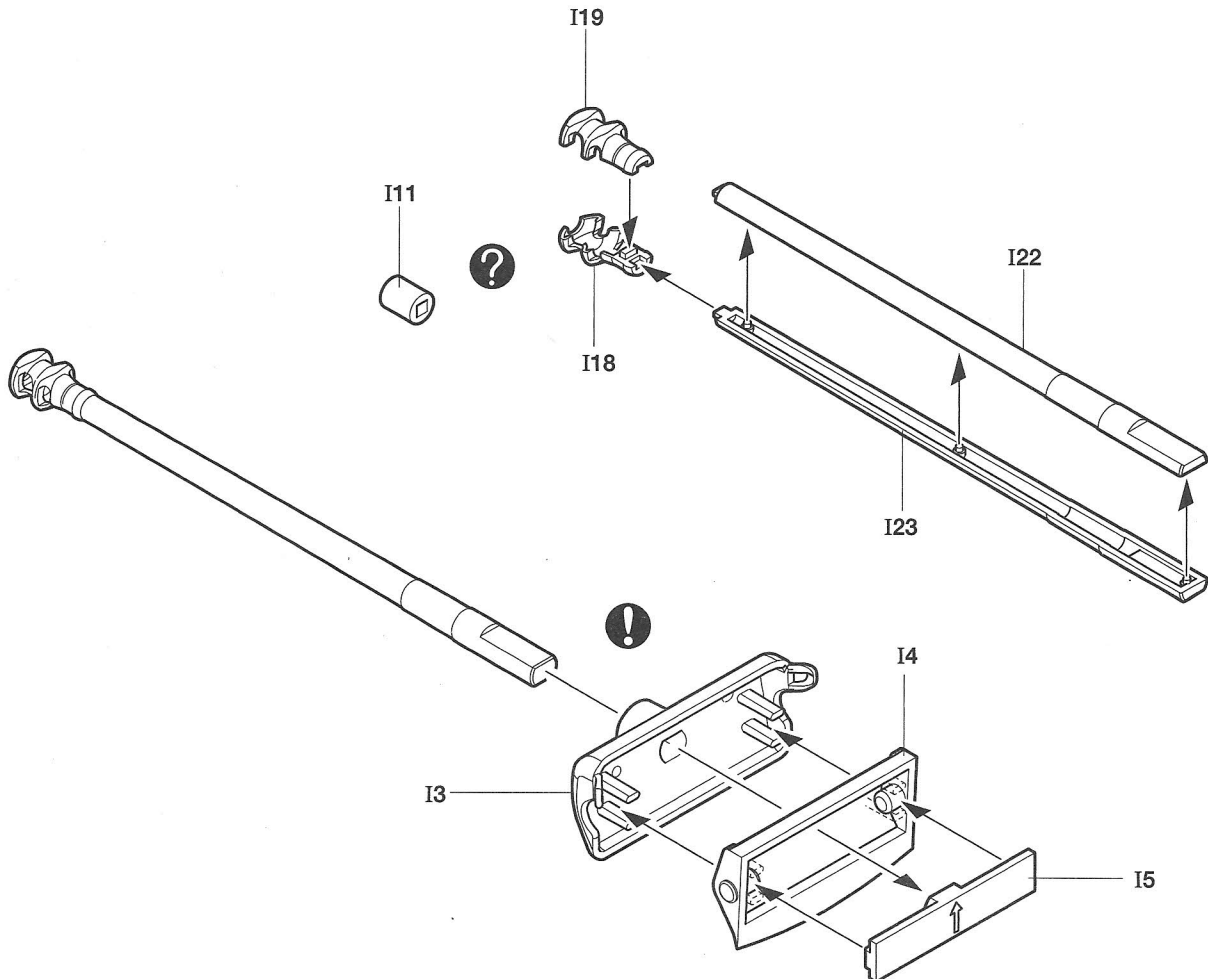

13

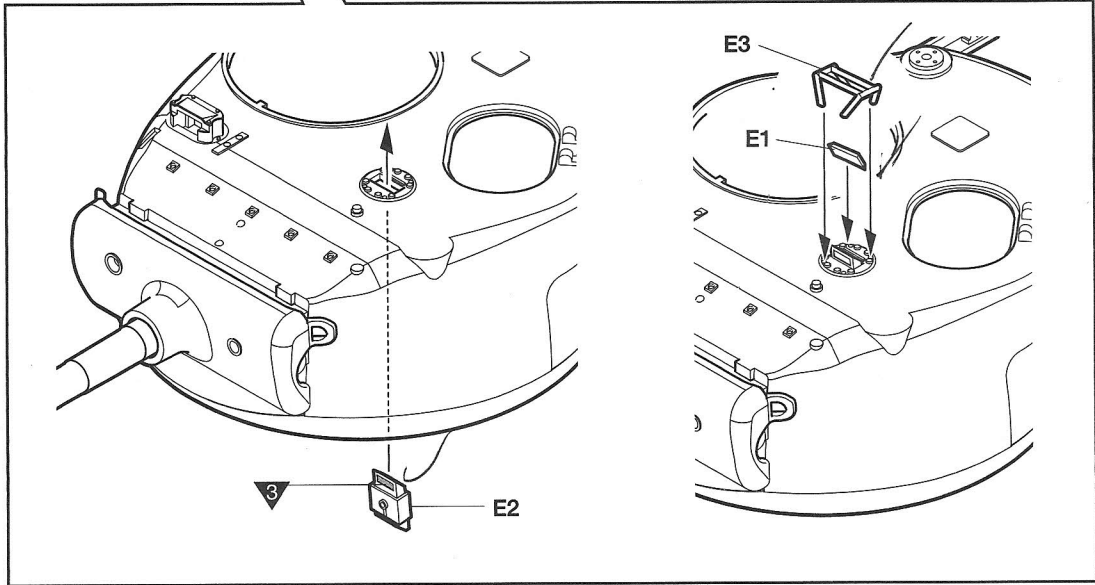
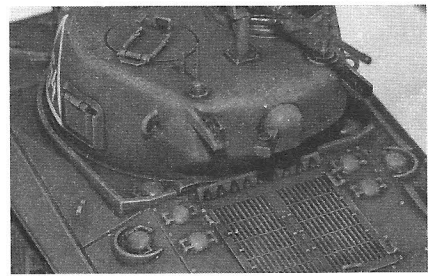
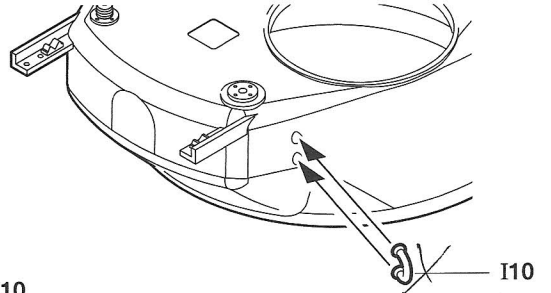
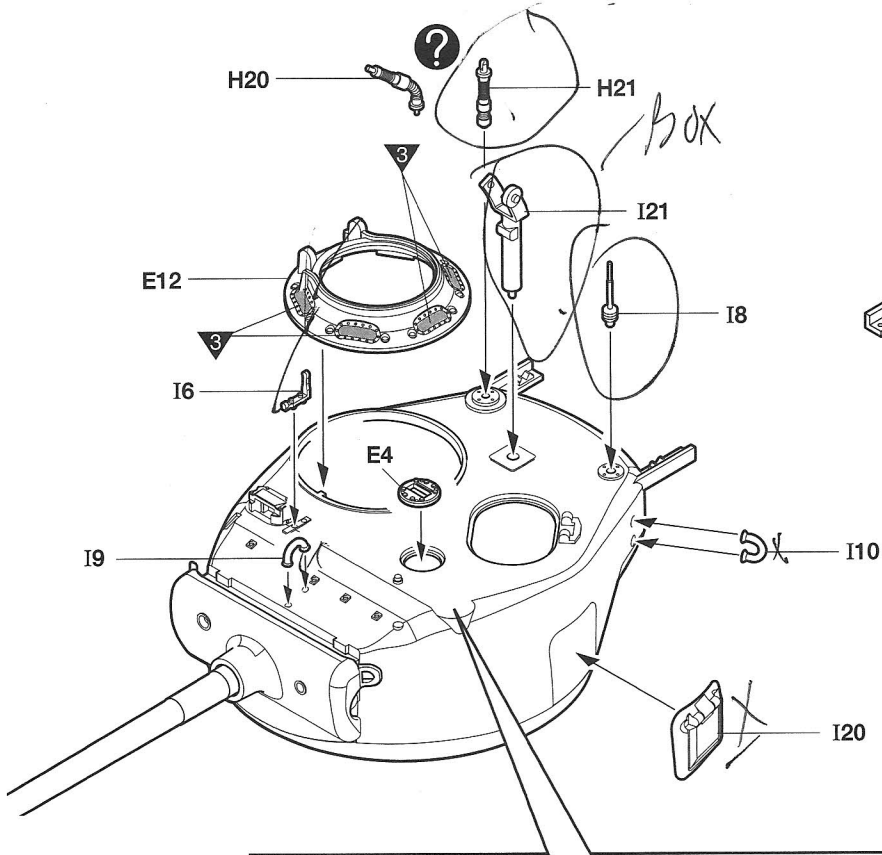
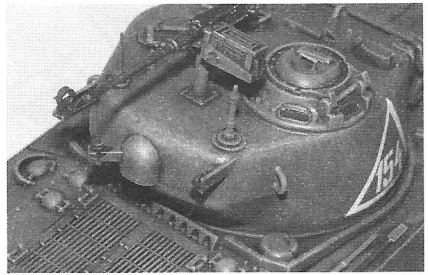
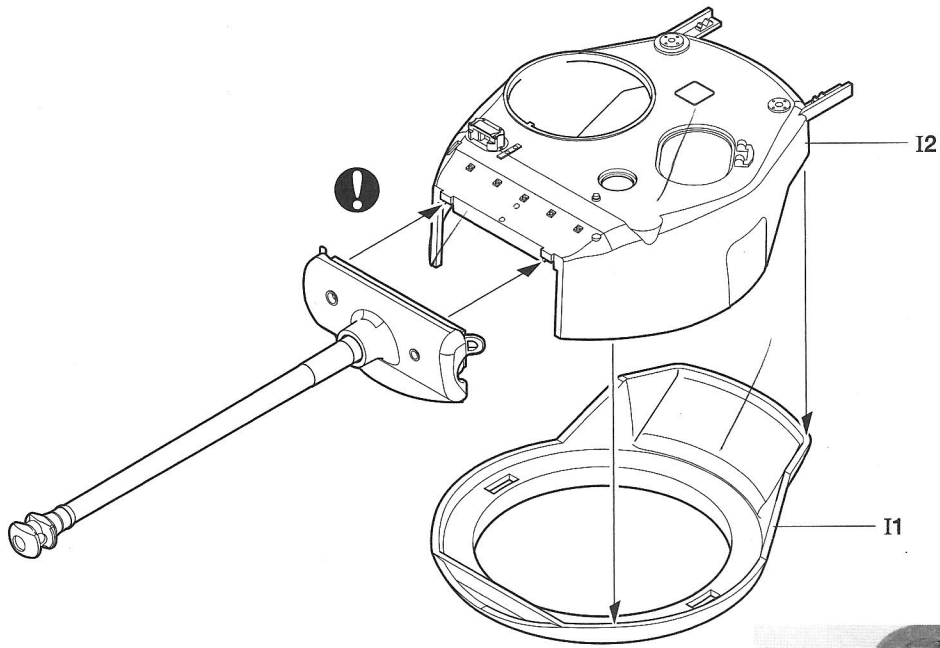

14

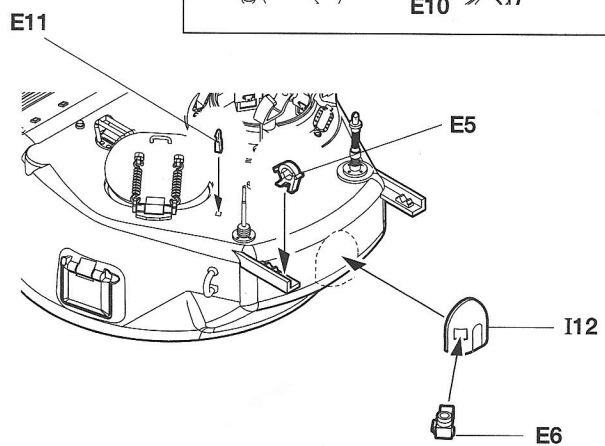
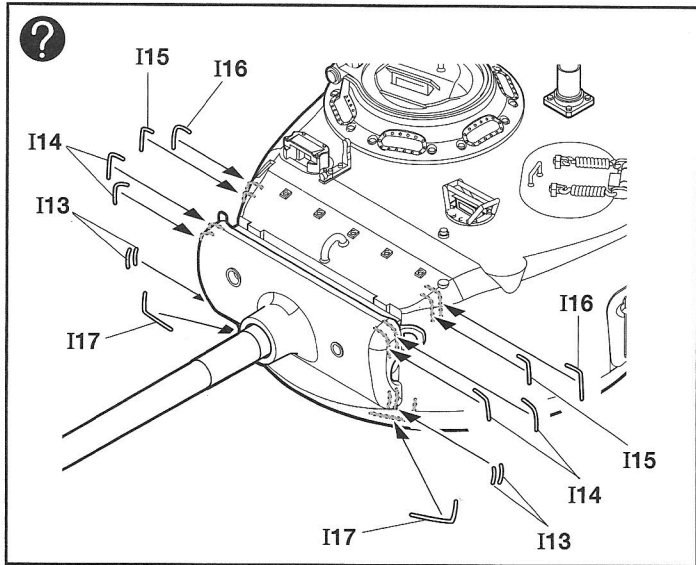
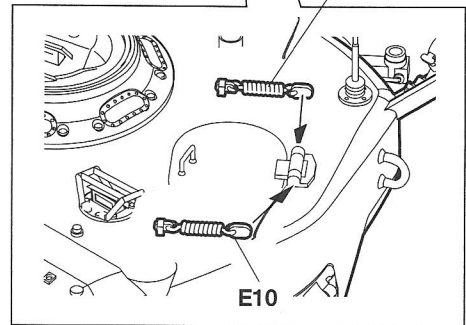
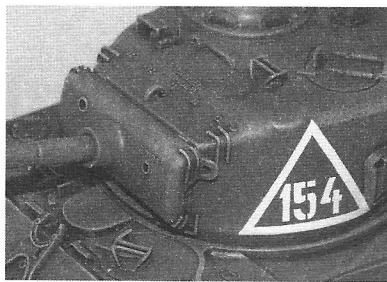
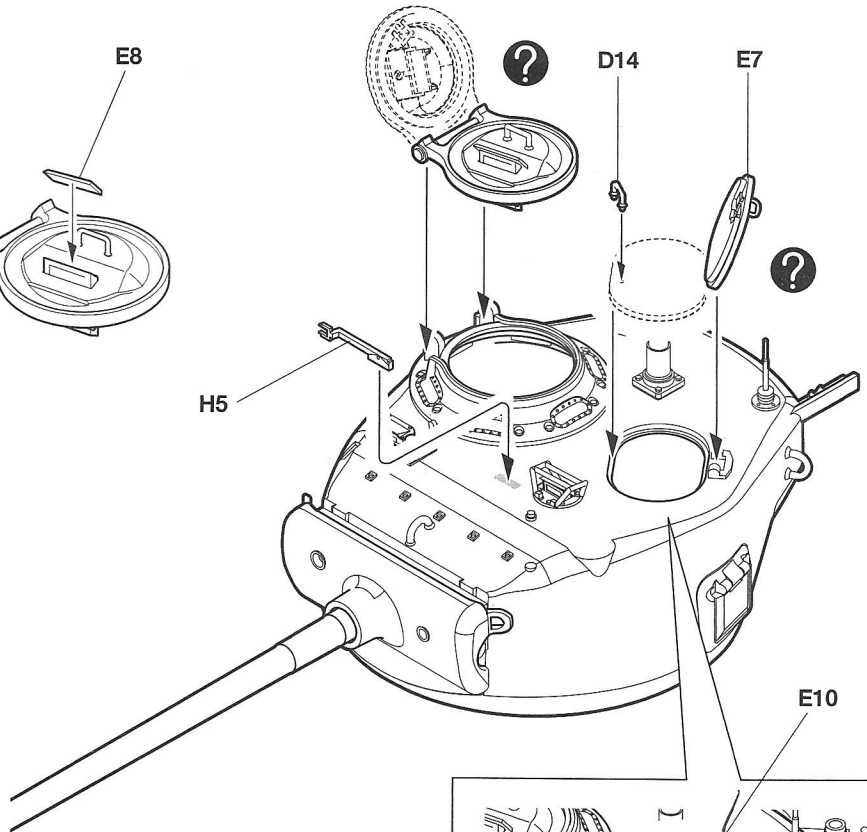
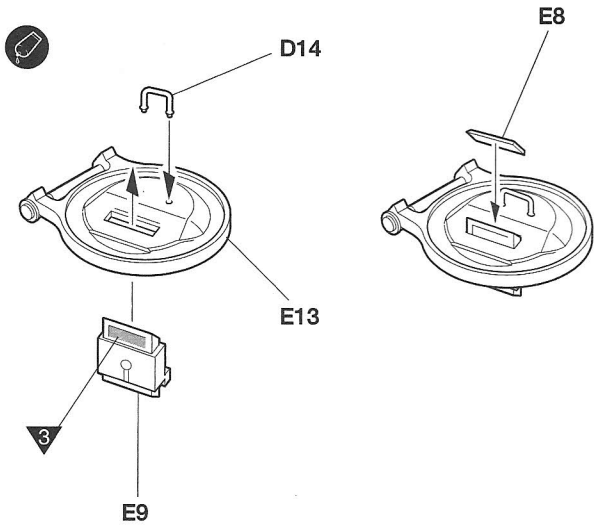

15

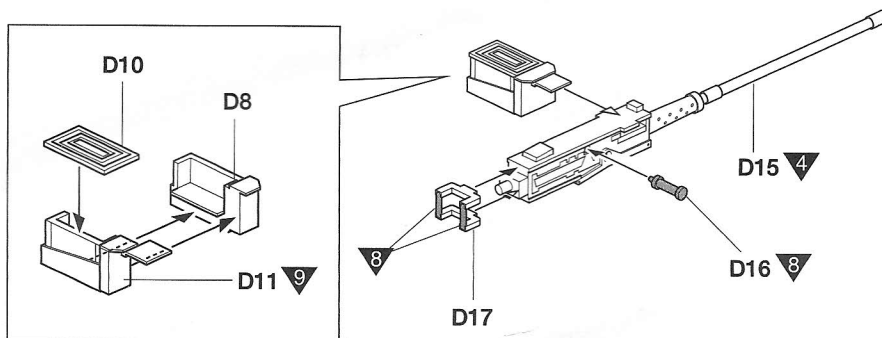

16

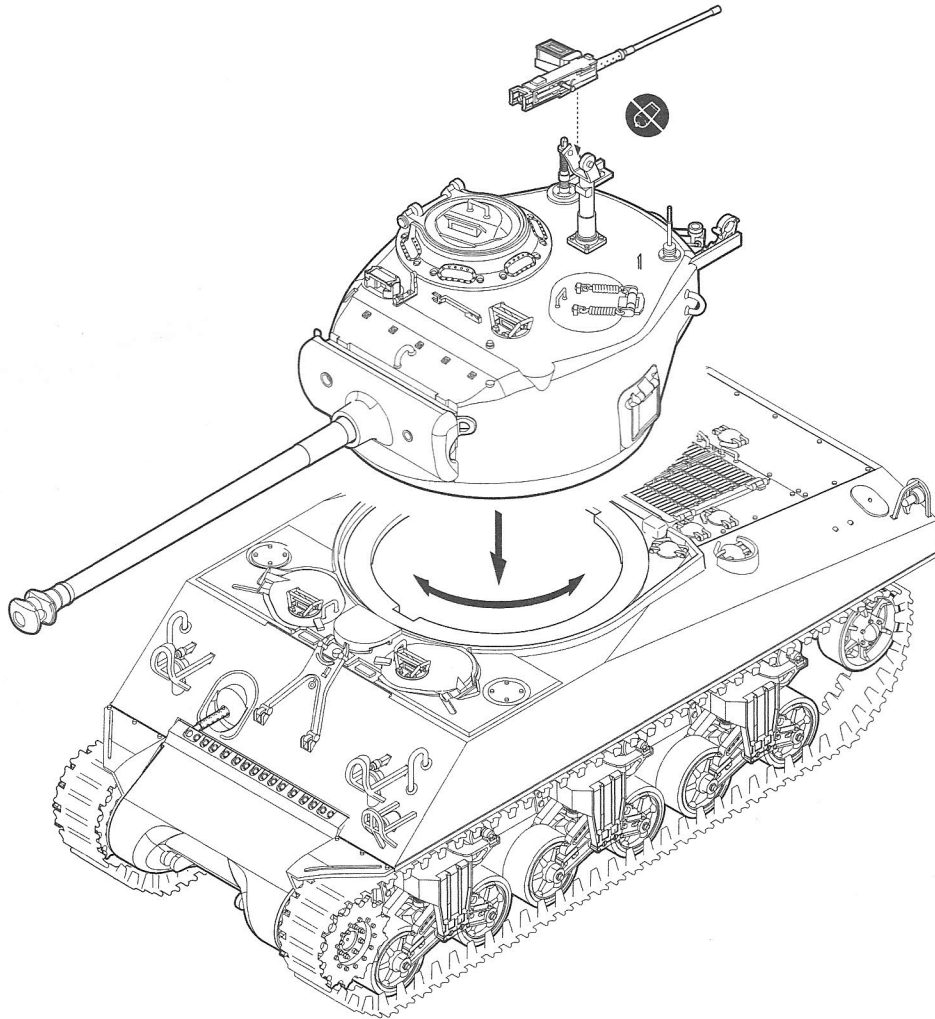

ACCESSORY PART

액세서리부품

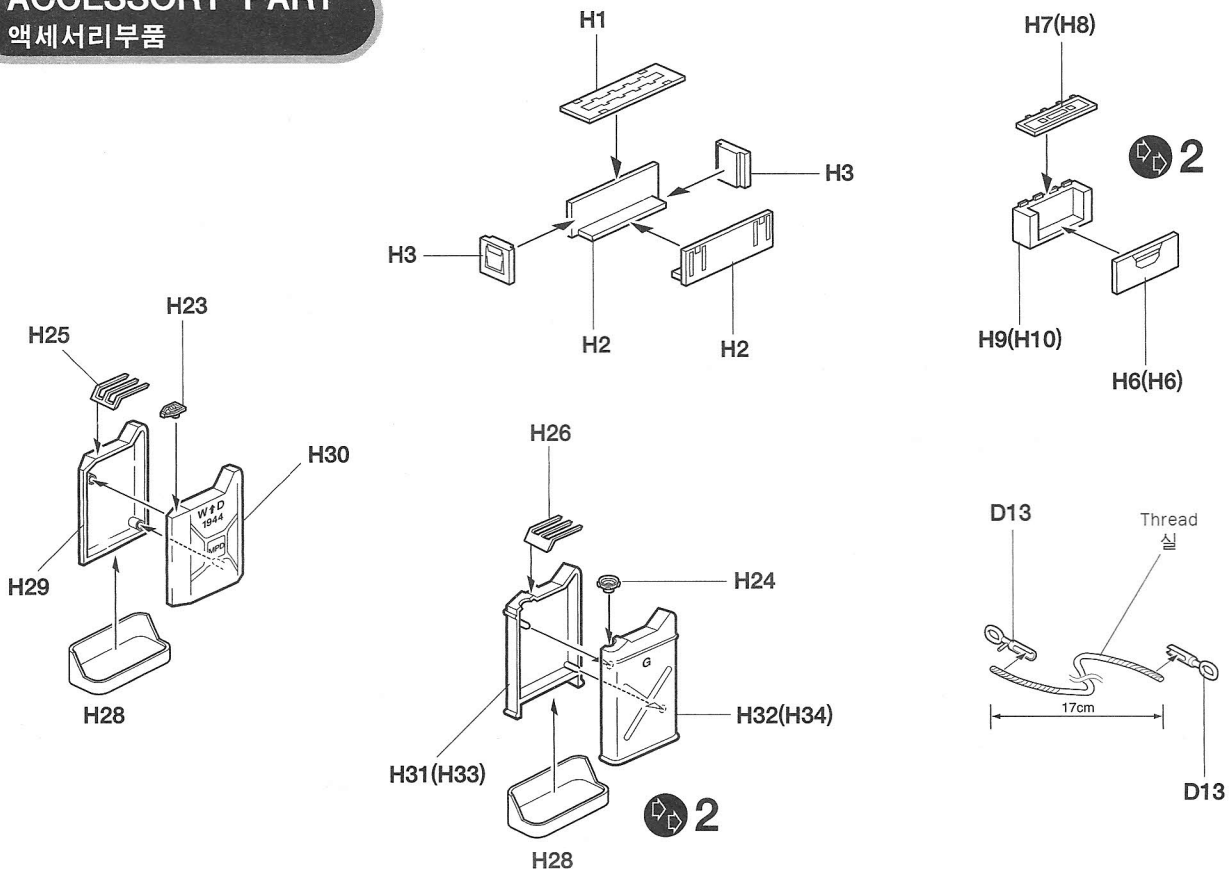

Painting & Decal placement 색칠 및 전사지 붙이기

1 Berlin, May 1945.
1945년 5월 베를린.

* () is opposite number.
()는 반대측 번호입니다.

Body Color : 9
차체색

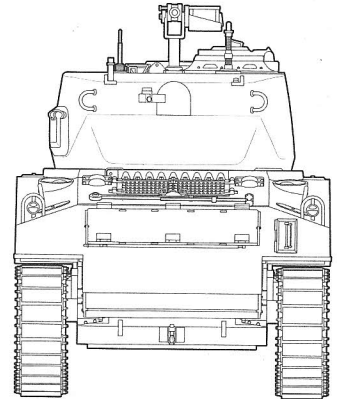
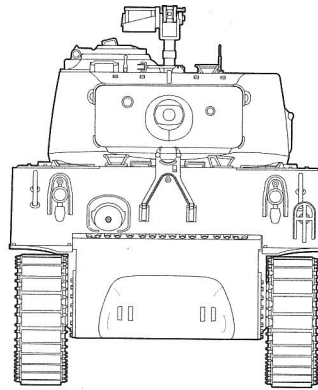
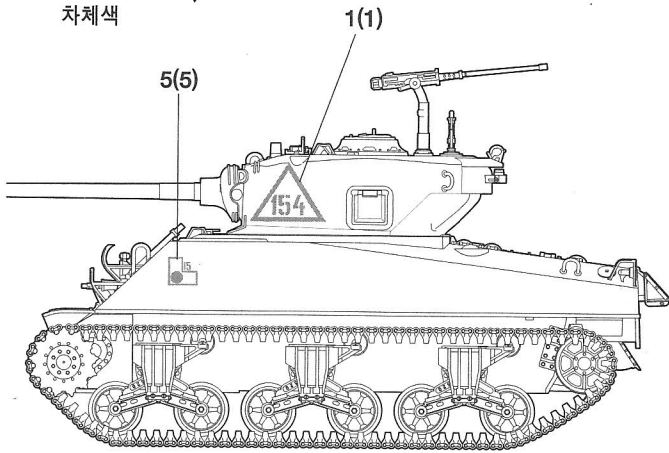

2 Berlin, April 1945.
1945년 4월 베를린.

Body Color : 9
차체색

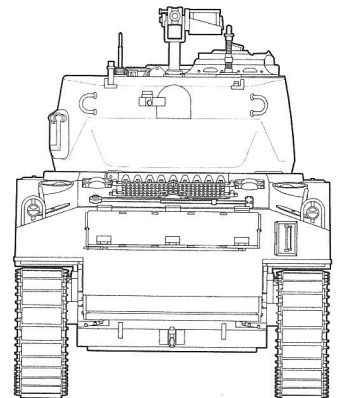
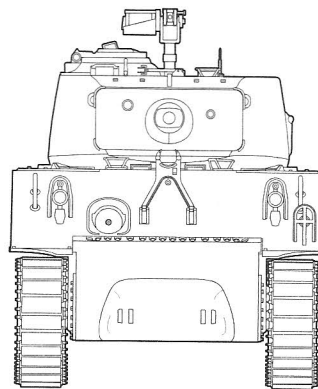
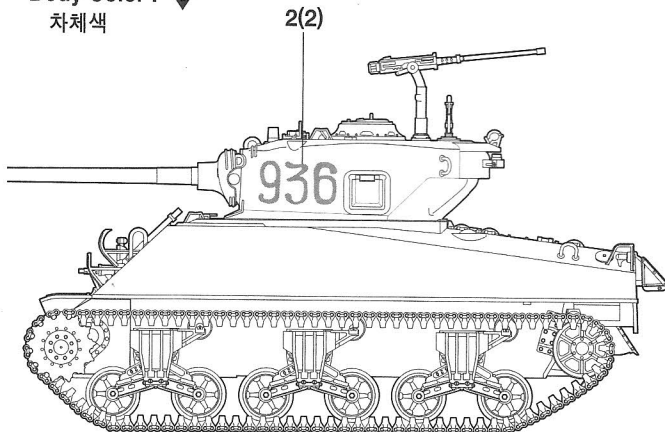

3 German, 1945.
1945년 독일.

Body Color : 9
차체색

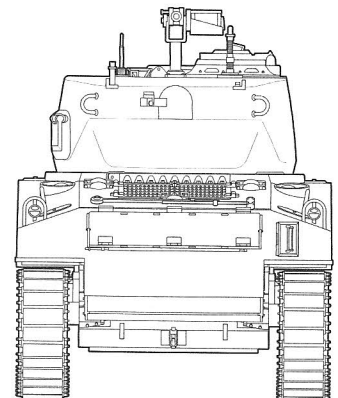
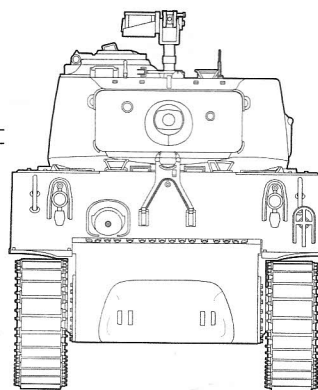
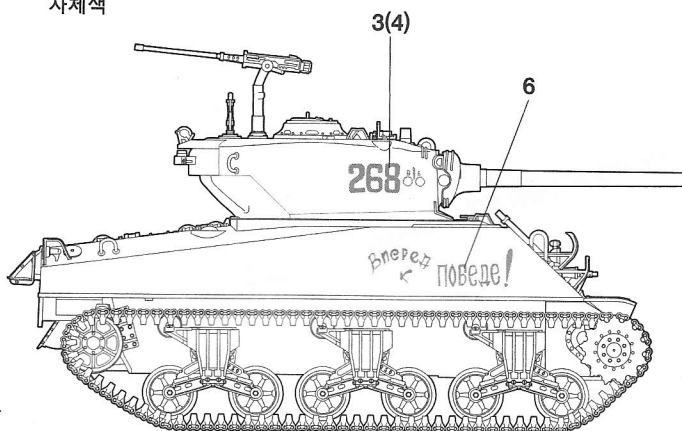

■ Parts Locating Diagram 부품도

A × 2

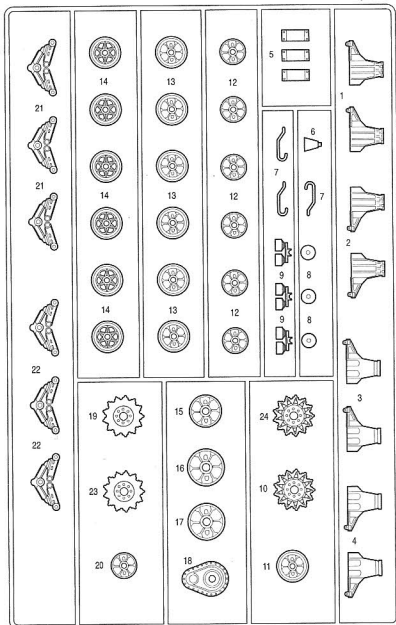

C

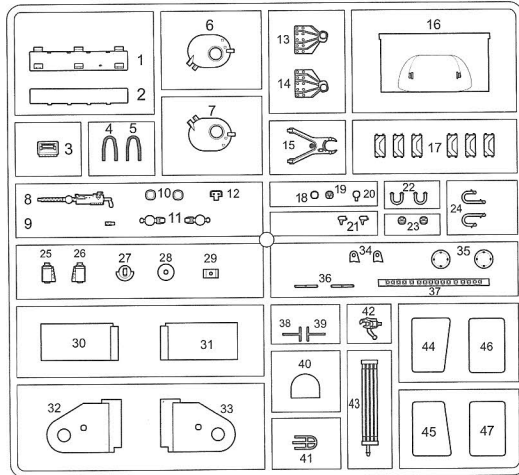

D

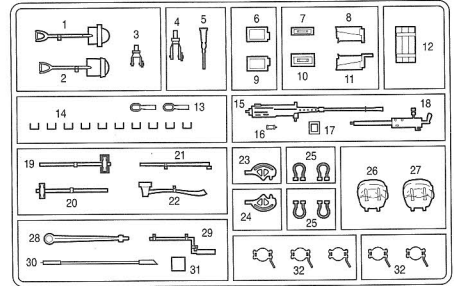

E

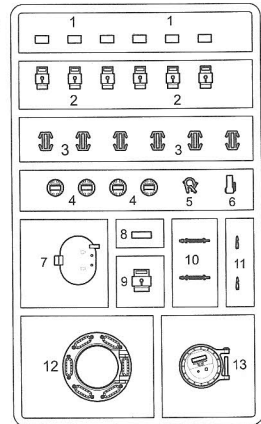

F

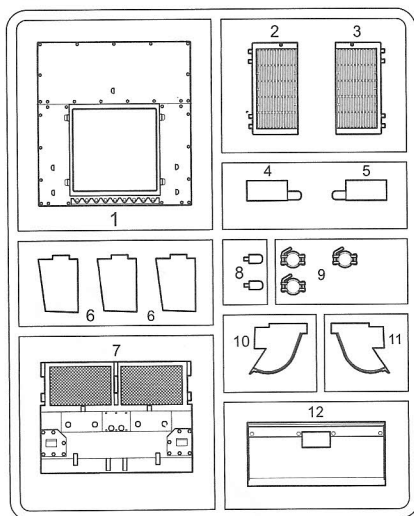

H

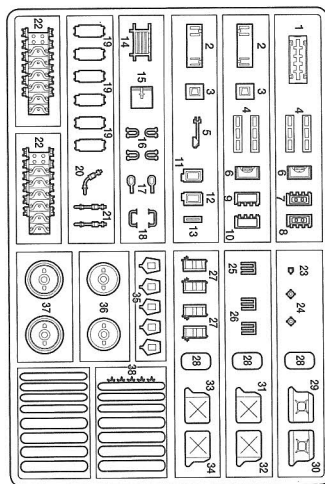

I

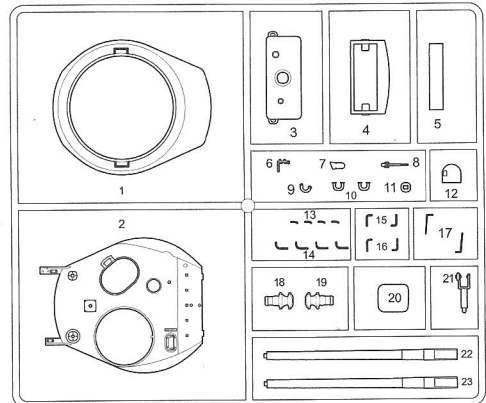

1	FLAT BLACK	MATTSCHWARZ	NOIR MAT	つや消しブラック	무광 검정색
2	BLACK	SCHWARZ	NOIR	블랙	유광검정색
3	BLUE	BLAU	BLEU	블루	유광파랑색
4	GUN METAL	METALL-GRAU	GRIS ACIER	گان메탈	건메탈
5	SILVER	SILBER	ARGENT	실버	은색
6	GOLD	GOLD	OR	골드	금색
7	KHAKI	KHAKI	KAKI	카키	카키색
8	LIGHT BROWN	HELLBRAUN	BRUN CLAIR	라이트브라운	라이트브라운
9	OLIVE DRAB	BRAUNOLIV	VERT OLIVE	올리브드라브	국방색

■ Unused parts : (A1, A2, A3, A4)×1, A5, A6, 불필요 부품 C9, C17, C18, C35×1, C44, C45, C46, C47, D1, D3, D4, D6, D7, D9, D14×4, D18, D19, D23, D24, D25×2, D29, D31, E1×1, E2×1, E3×3, E4×1, E11×1, H4, H11, H12, H13, H14, H15, H16×2, H17, H18, H19, H21×1, H22, H27, H35, I7

■ Accessory parts: A11, A20, D12, D26, D27, 액세서리 부품

■ Upper Hull 상체 × 1 ■ Lower Hull 하체 × 1
 ■ Flexible Track 연질캐터필러 × 2 ■ Thread 실 × 1
 ■ Decal 전사지 × 1

■ 직매점 겸 A/S센터
 ■ A / S 센터
 ■ 총판점 겸 A/S센터

■ 유통사업부
 ■ 홈페이지
 ■ 고객상담문의

상선교: 742-9293, 방배동: 552-9293, 양재동: 575-9997, 용산: 796-1214, 아셈하비센터: 6002-6293, 구로하비나라: 853-9293
 본사: 908-7000(교환147), 동대문: 745-9293,
 원아카데미: 907-0940, 양천아카데미: 2691-7108, 강남아카데미: 485-6884, 강북아카데미: 762-0980,
 AB하비: (031)458-5591, 서면아카데미: (051)816-9773, 대구아카데미: (053)744-9293
 아카데미피렌드: 586-9293
<http://www.academyhobby.com>
 080-969-7000

ACADEMY HOBBY MODEL KITS **ACADEMY PLASTIC MODEL CO., LTD.**
 273-64, Suyu-dong, Kangbuk-gu, Seoul, Korea
 TEL: 82-2-908-7000 FAX: 82-2-997-3003