

LONG RANGE  
DESERT GROUP

CHEVROLET

30cwt  
TRUCKTAMIYA PLASTIC MODEL CO.  
3-7, ONDWARA, SHIZUOKA-CITY, JAPAN

1/35 MILITARY MINIATURE SERIES



The military value of motor vehicles in desert terrain had been proved to some extent during World War I. British Forces had used such vehicles as Rolls-Royce Armoured cars and Ford Model T light trucks with great success. One British staff officer who was greatly influenced was Archibald Wavell, and when in 1936 he had Fox Davies placed in command of a Unit which was sent behind the 'enemy lines' - with great success - in a military exercise. A British group of explorers, led by R. A. Bagnold, made many expeditions into the desert in the late 1930s from Egypt, studying the desert and its characteristics, and perfected ways of navigating across the vast desert wastes like a mariner at sea. In 1940 Italy declared war on Great Britain, and the Italian forces in Libya posed an immediate potential threat to the British in Egypt, and to the Suez Canal the 'gateway' to the East. General Wavell was the British Commander-in-Chief in Egypt at the time, and he took R. A. Bagnold into the Army as an officer and gave him the job of forming a motor patrol. The LRDG was very much like a 'private army', formed to meet the peculiar conditions of desert warfare. Major Bagnold (as he then was) acquired suitable vehicles, and the Chevrolet 15 cwt truck used by the Egyptian Army suited his needs. This was a standard 'platoon' truck on a Canadian-built Chevrolet chassis, fitted with desert tyres and with an open body big enough to hold the stores and equipment needed for long trips into the desert. For desert operations with a very heavy load, they had extra leaves inserted into the springs, desert tyres, wireless, and a condenser fitted on the running board and connected to the radiator to conserve cooling water. Doors and door pillars were removed, extra spare wheels fitted, and pintle mounts were added for machine guns and antitank rifles. The load carried might be up to two tons, consisting of food, fuel, ammunition, water and explosives for demolition

work. Sand-mats of canvas and steel sand channels were carried to assist vehicles through the many shifting sands and dunes. A sun compass was usually carried on the dashboard - Bagnolds' invention and theodolites and sextants were used to fix positions. The Long Range Desert Groups' task for most of the time was - watching, waiting, plotting enemy movements and reporting back by radio. The LRDG took delivery of new vehicles in May 1942, namely 30 cwt types with military general service steel bodies. These were sturdier than the original type of vehicle and more capacious. Built by Chevrolet (Canada) these were simply a desert service version of the standard production Chevrolet types. Because the LRDG was made up of volunteers it never really had regimental status. The men wore whatever clothes were comfortable. Beards and other non-regulation military practices were common, adding much to the 'piratical' flavour and swash-buckling image of the LRDG Force.

#### Vehicle Data

Chevrolet 30 cwt 4 × 2 General Service Lorry.

Wheelbase: 134 inches.

Net Weight: 6,540 lbs.

Engine: 6 cylinder petrol of 235.5 cu.in. capacity. 80 BHP at 3,100 rpm.

Gears: 4 forward, 1 reverse.

Tyres: 10.50 × 16 Runflat type.

Der militärische Einsatz von Kraftfahrzeugen in der Wüste wurde bereits im 1. WW erkannt. Mit grossem Erfolg setzten die Briten Rolls-Royce und auch Ford Model T als leichte Lastkraftwagen mit Panzerung ein.

Sehr beeindruckt davon war der Stabsoffizier Archibald Wavell und als er Ende der 30er Jahre General wurde, war er für die Idee empfänglich, kleine motorisierte Einheiten, in Einsatz zu bringen. Im Oktober 1935 schrieb bereits der Leutnant Fox Davies der Durham Light Infantry an den General und schlug vor, Guerillakämpfer hinter die Fronten zu bringen.

Lt. Davies bekam das erste Kommando und in einer militärischen Übung zeigte sich der grosse Erfolg. Ende 1930 machte der bekannte Forscher R.A. Bagnold viele Expeditionen in die Wüste und entdeckte neue Wege der Navigation - ähn-

lich der, der Seeleute. 1940 erklärte Italien den Krieg gegen England mit einem schnellen Vormarsch aus Lybi en nach Ägypten, in Richtung Suezkanal.

Oberbefehlshaber in Ägypten war der General Wavell. Bagnold wurde als Offizier verpflichtet und bekam den Auftrag, eine motorisierte Patrouillenabteilung aufzubauen - das L.R.D.G. (Long Range Desert Group) Dieses L.R.D.G. war ähnlich einer Privatarmee, speziell für den Einsatz in der Wüste - hinter der Front. Major Bagnold verlangte ein Fahrzeug und der Chevrolet 15 cwt Truck der Armee entsprach seinen Vorstellungen. Dieses in Kanada gebaute Fahrzeug war ein Standard Truck, mit Wüstenreifen und offenem Laderraum, gross genug für die benötigte Ausrüstung. Für die schweren Lasten wurden Zusatzblätter in die Federung eingebaut, Funk und Radiogerät, Zusatztanks für Wasser auf den Trittbrettern, Türen entfernt und Ersatzreifen angebracht, Drehzapfen für MG und Panzerbüchsen, Sandmatten und Sandbleche. Die Verpflegung, Munition, Wasser und Sprengmaterialien etc. hatten ein Gewicht von über 2 Tonnen. Bagnolds Erfindung - ein Sonnenkompass, Höhenwinkel-Messgerät und Sextanten zur Standortbestimmung waren ebenfalls in diesem Fahrzeug eingebaut. Der Einsatz der LRDG war meistens das Beobachten und Erkundigungen des Feindes, Anschlüsse auf feindliche Basen und Mitteilung der Berichte an das Armeekommando durch Funk. 1942 im Mai kamen neue Fahrzeuge zum Einsatz, 30 cwt, besser ausgestattet und grossräumiger, auf Grund der bisherigen Erfahrungen, unter Verwendung der in Kanada gebauten Standard Trucks, von Chevrolet.

Das LRDG bestand nur aus Freiwilligen und hatte keinerlei militärisches Aussehen. Die Männer trugen Kleidung wie immer sie es für notwendig befanden - also keine Uniformen - dafür aber Bärte wie Seeräuber. Daten  
Chevrolet 30 cwt 4 × 2 General Service Lorry  
Radstand 340 cm, Nettogewicht 2966 Kilo  
Motor 6 Zylinder Benzin, 3,86 cc, 80 BHP bei 3100 rpm, 4 Vorwärts- 1 Rückwärtsgang,  
Reifen 10,50 × 16 Runflat.

**READ BEFORE ASSEMBLY.**

**ERST LESEN — DANN BAUEN.**



★ Study the instructions and photographs before commencing assembly.

★ You will need a sharp knife, a pair of pliers, a file, and a pair of tweezers.

■ This mark shows the colour this part should be painted. See also page 6

★ Vor Beginn die Bauanleitung Studieren und den Nummern nach die Elemente zusammenbauen.

★ Kleine Teile hält man mit Pinzette fest.

■ Zeichen für Bemalung.

**2** <<Wheels>>  
<<Räder>>

C45, D2 and C16 are designed to rotate. Do not cement.

C45, D2 und C16 sind drehbar. Nicht kleben.

**3** <<Front Axle>>  
<<Vorderrad Radachse>>

C26 and C27 are movable. Do not cement. Teile C26 und C27 sind beweglich. Nicht kleben

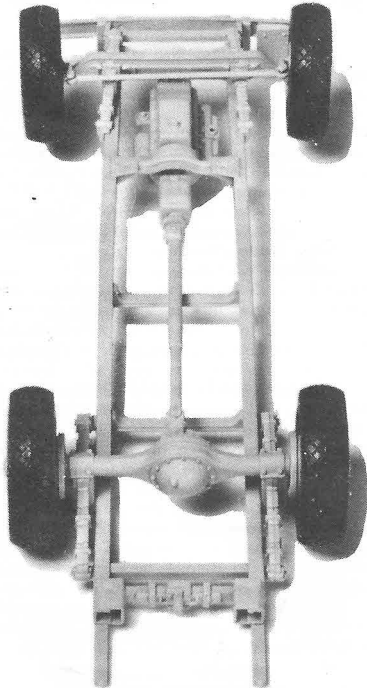

**1** Fixing of Suspension  
Einbau der Radaufhängung

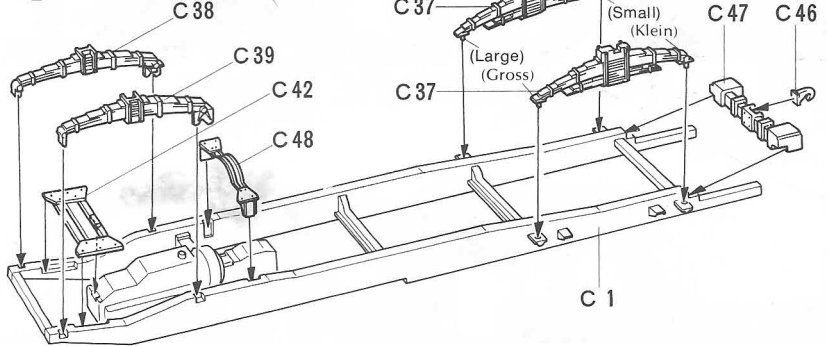

**2** Construction of Wheels  
Zusammenbau der Räder

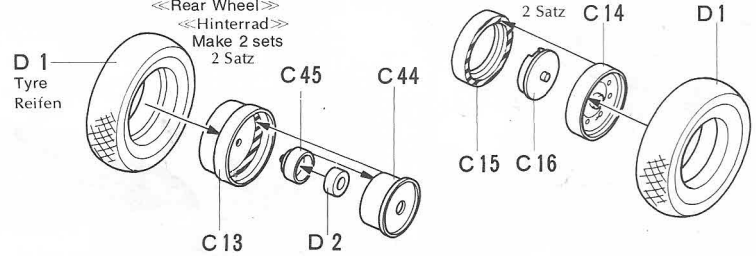

**3** Front Axle  
Vorderrad Radachse

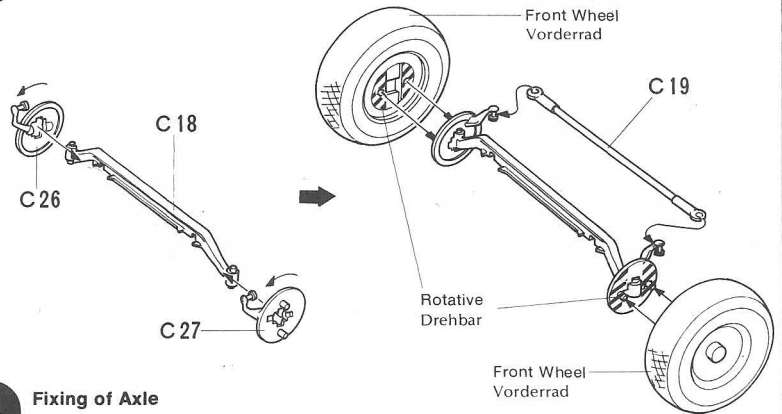

**4** Fixing of Axle  
Radachsen

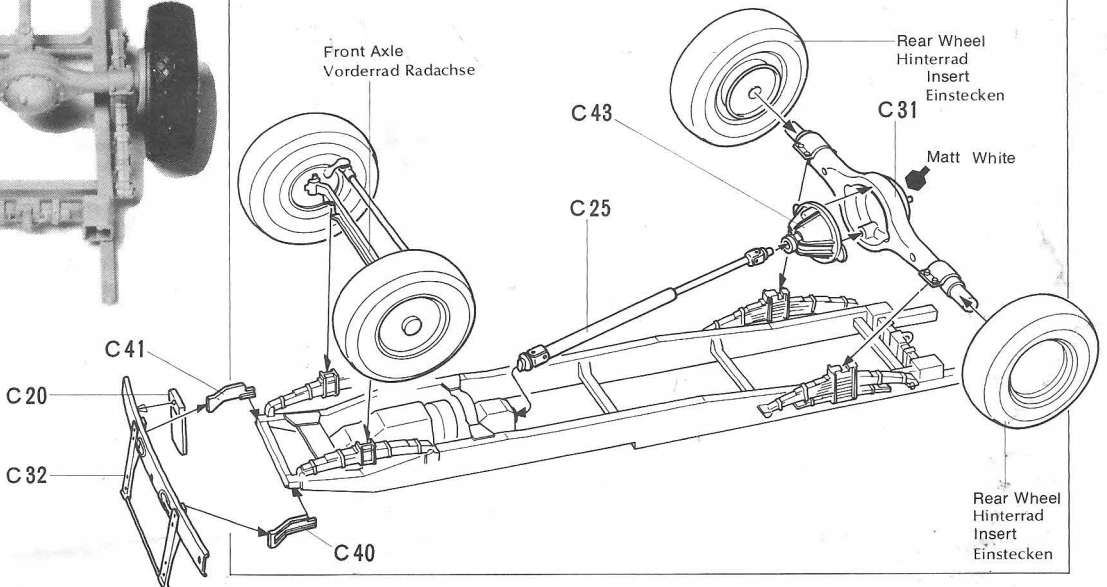

**5** <<Bonnet>>  
<<Haube>>

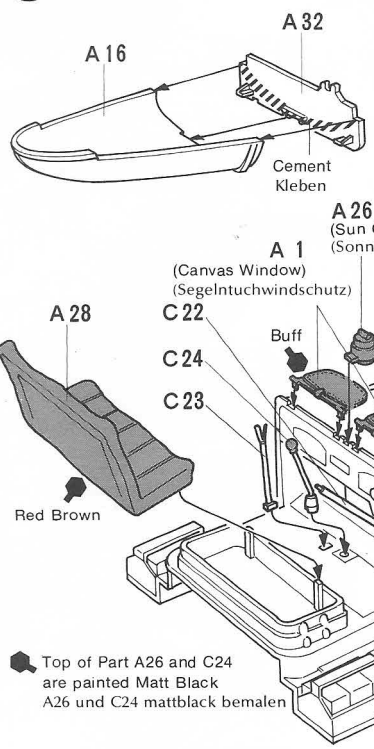

**5** Bonnet  
Haube

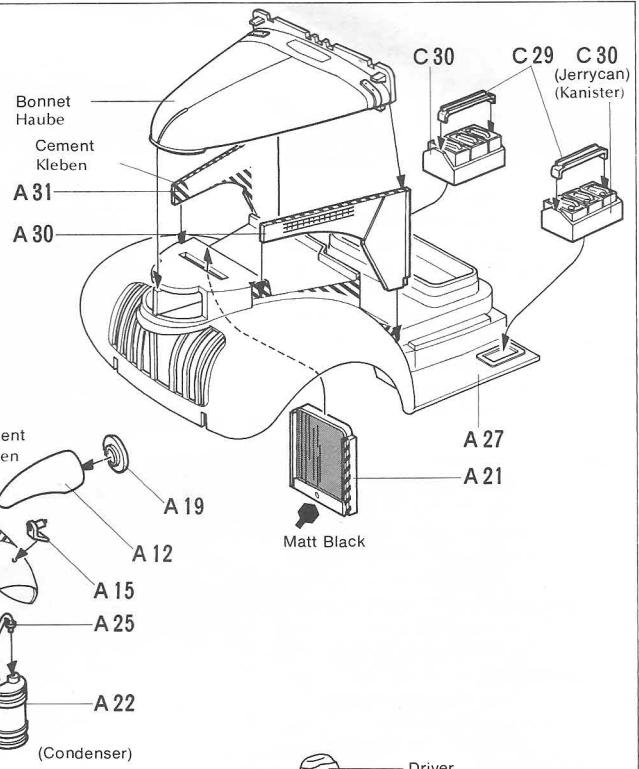

**6** <<Cockpit>>  
<<Fahrersitz>>

<<Construction of Figure>>  
<<Männchenbau>>

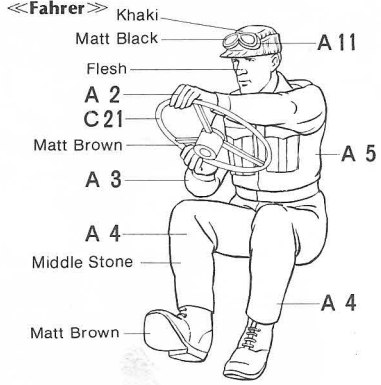

<<Navigator>>  
<<Seefahrer>>

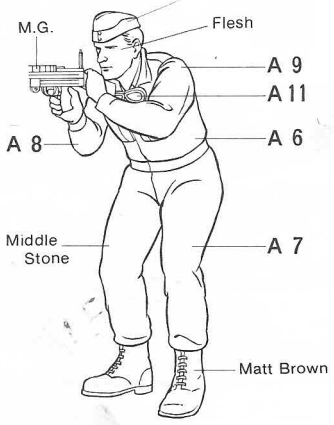

**6** Cockpit  
Fahrersitz

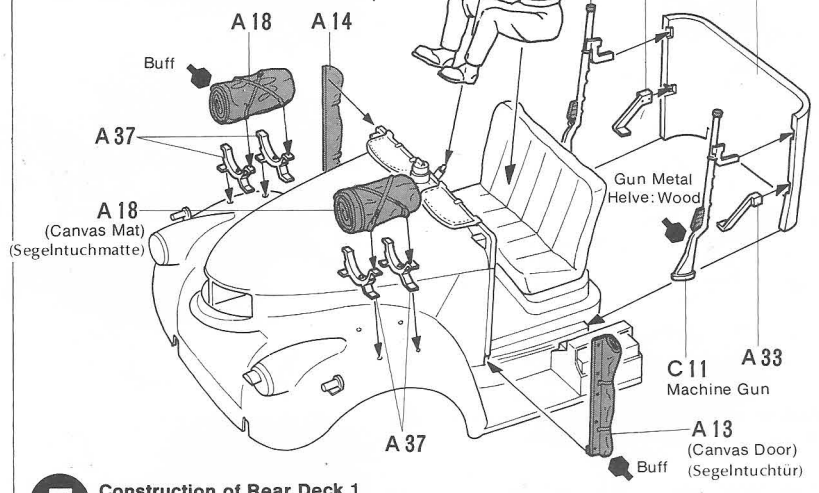

**7** Construction of Rear Deck 1  
Bau des Fahrzeughecks 1

B9, B10 and B14 are inserted without glue before fixing Radio.  
★ Erst B9, B10 und B14 einstecken, dann Radio aufkleben.

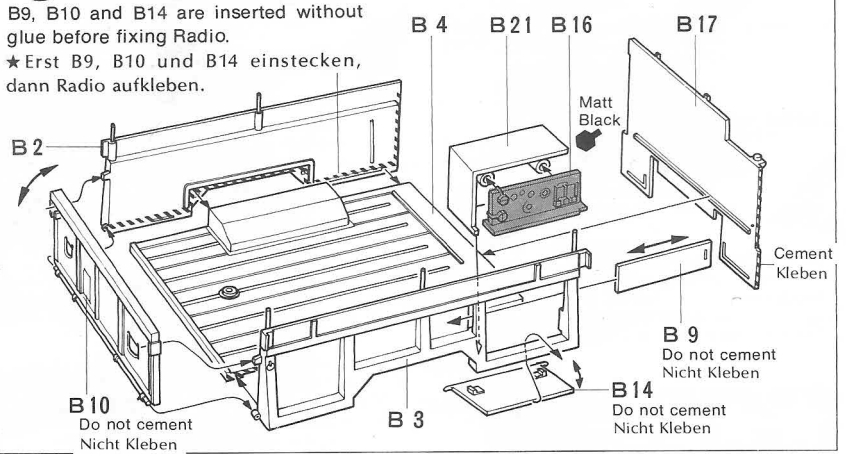

Construction of Rear Deck 2  
 Bau des Fahrzeughecks 2

**8** Construction of Rear Deck 2  
 Bau des Fahrzeughecks 2

(Open position)



(Closed position)

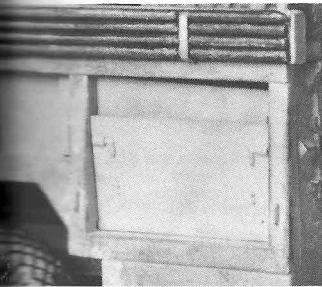

Machine Gun  
 Maschinengewehr

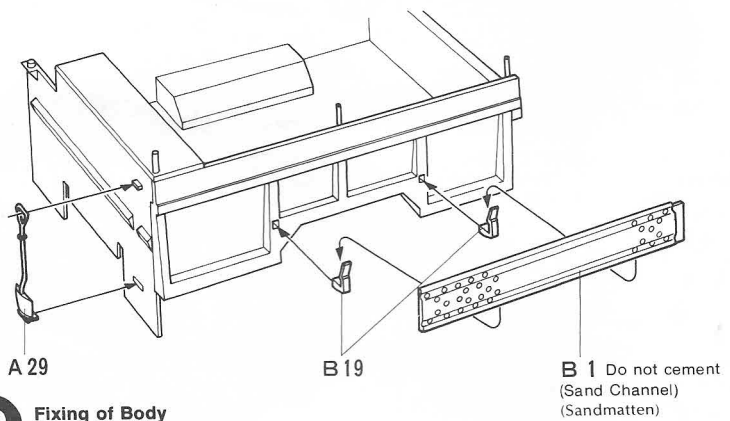
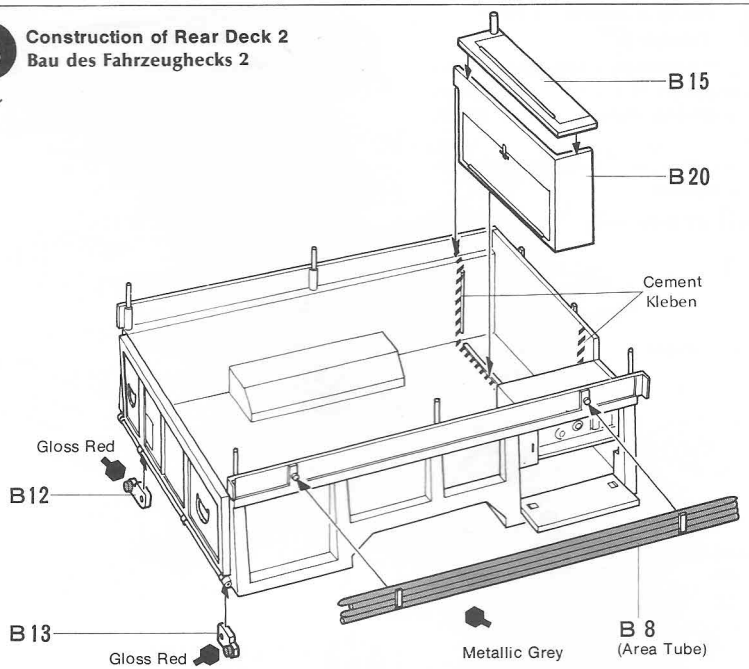
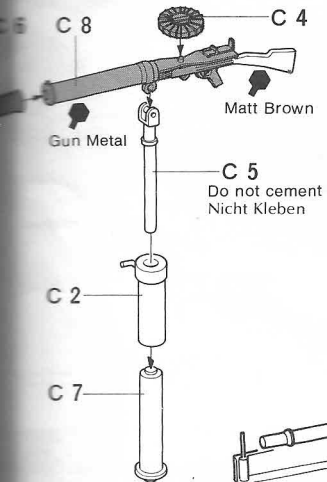

**9** Fixing of Body  
 Einbau der Aufbauten

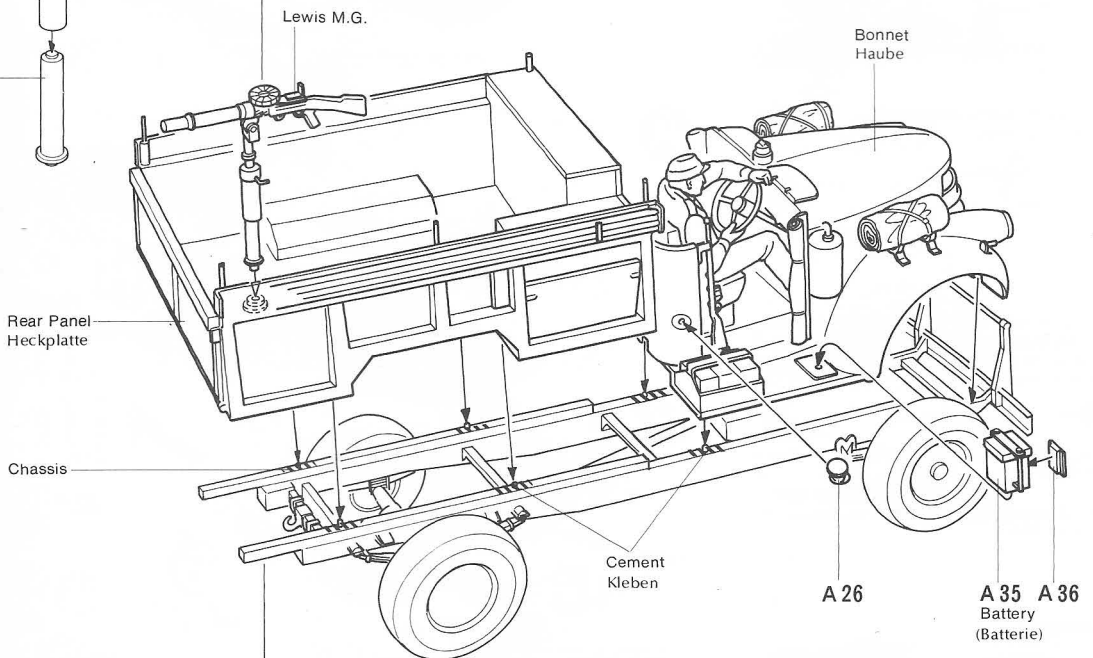

# 11 << Fixing of Accessory Parts >> << Zubehör >>

Fixing of Accessory Parts may be done with reference to the photographs and your additional material or your preference.

Zubehör kann wie im Bild gezeigt eingebaut werden

## << Boys AT Rifle >>



## << Spare Wheel >>

### << Ersatzrad >>

D 1 C 17

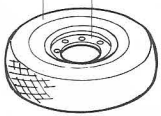

## << Water Tank >>

### << Wasserkasten >>

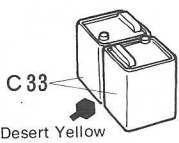

## << Wood Box >>

### << Kasten >>

C 34 Red Brown

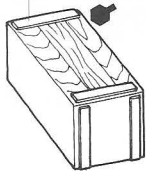

## << Marine Sack >>

### << Sack >>

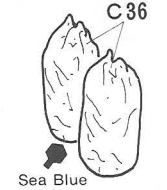

## << Sleeping Bag >>

### << Schlafsack >>

C 35

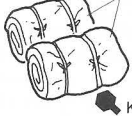

## << Water Canteen >>

### << Feldflasche >>

B 7

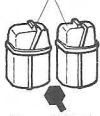

## << Helmet >>

### << Helm >>

A 10



## << Receiver >>

### << Hörer >>

B 18



## << How to make Antenna >>

### << Antennenbau >>

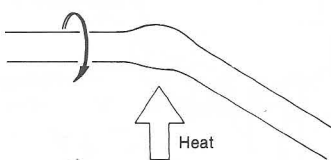

Heat a length of sprue. When melted a little, stop heating and pull to stretch it. Hold for about 15 seconds to cool and cut to proper length.

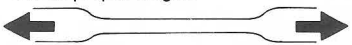

Ein Stück vom Spritzling über Kerze gerade biegen. Dann in der Mitte im Drehen erhitzen. Wenn Plastik schmilzt, nicht weiter erhitzen und langsam auseinanderziehen.

# 10 Fixing of Muffler Auspuff

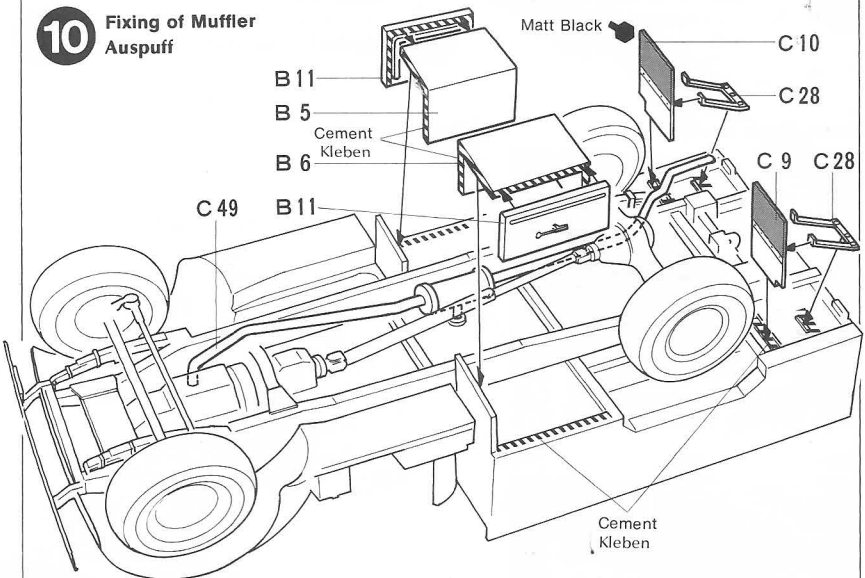

# 11 Fixing of Accessory Parts Zubehör

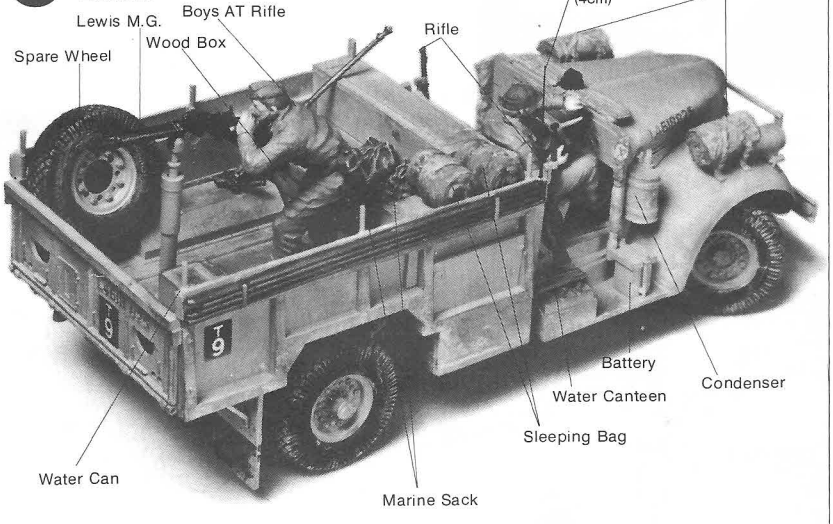

## PARTS

A

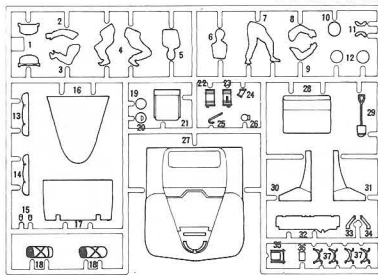

B

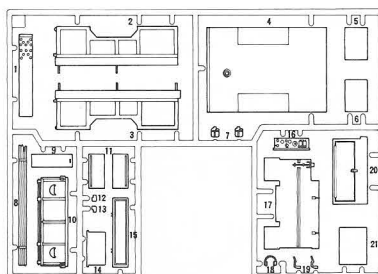

C

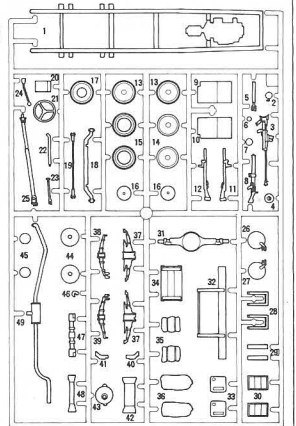

D

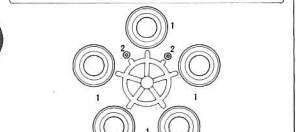

# PAINTING



# APPLYING DECALS

## <<Painting of Desert Chevrolet>>

Most of desert chevroleets were painted either plain colour or middle stone. Some had the standard BS pink as it actually gave better concealment than sand colour, due to the reddish reflection at sunset or sunrise. As a camouflage finish, vehicles were painted slate blue over middle stone, which pattern peculiar to British Army.

## <<Bemalung Chevrolet>>

In der Britischen Armee wird die einheitliche Farbe für Militärfahrzeuge verwendet: dunkel grün. Zur Tarnung werden mattschwarze und rotbraune Flecken aufgetragen. Im Wüsteneinsatz wird - pink - verwendet' da diese Farbe wesentlich besser als die Farbe - sand - geeignet ist und bei Sonnen Aufgang und Untergang rötlich wirkt. In der Wüste wird auch zur Tarnung schieferblau auf mittelsteingrau verwendet.

## <<Colour to be used>>

### <<Farben>>

- Matt Black
- Matt White
- Light Blue
- Khaki
- Buff
- Desert Yellow
- Dark Yellow
- Red Brown
- Gun Metal
- Middle Stone
- Metallic Grey

## <<Marking of Desert Chevrolet>>

### <<Markierung>>

Applying decals refer to the figure on the right for this.

Abziehbild: Siehe Zeichnung

### Tamiya Acrylic Paints

Need precise colour matching? Try the new Tamiya acrylic paints. Engineered by modelers for modeler's use. The final cover for the finest models. Insist on Tamiya for perfect results.



### TAMIYA COLOR CATALOGUE

The latest in cars, boats, tanks and ships. Motorized, radio controlled and museum quality models are all shown in full color in Tamiya's latest catalogue. At your nearest hobby supply house.



**TAMIYA**  
TAMIYA PLASTIC MODEL CO.  
3-7, ONDWARA, SHIZUOKA-CITY, JAPAN.

## <<Marking of L.R.D.G.>>



Desert Yellow

L4618925  
or L4618345

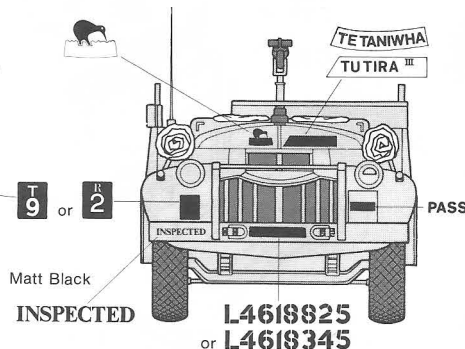
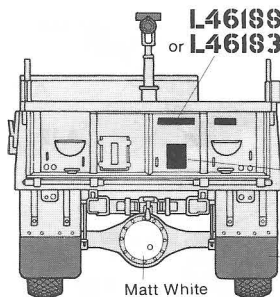
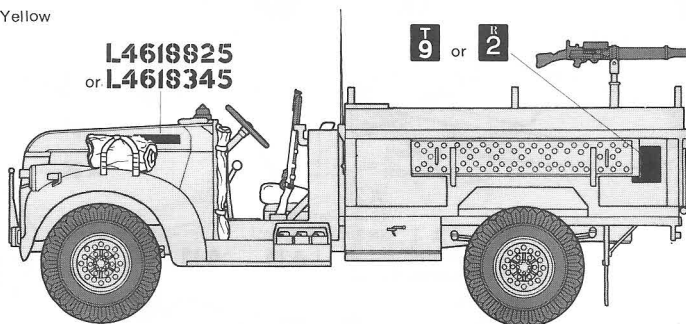

## <<Camouflage painting of L.R.D.G.>>

### <<Tarnanstrich>>



Middle Stone



Light Blue

